



**System Management
Interface Forum**



**Power Management Bus
Implementers Forum**

Introduction To The PMBus™

**Presented By
Robert V. White, Artesyn Technologies;
Chair, PMBus Specification Working Group**

May 2005

www.powerSIG.org

What Is PMBus?

What Is PMBus?

A Standard Way
To Communicate
With Power Converters
Over A Digital
Communications Bus

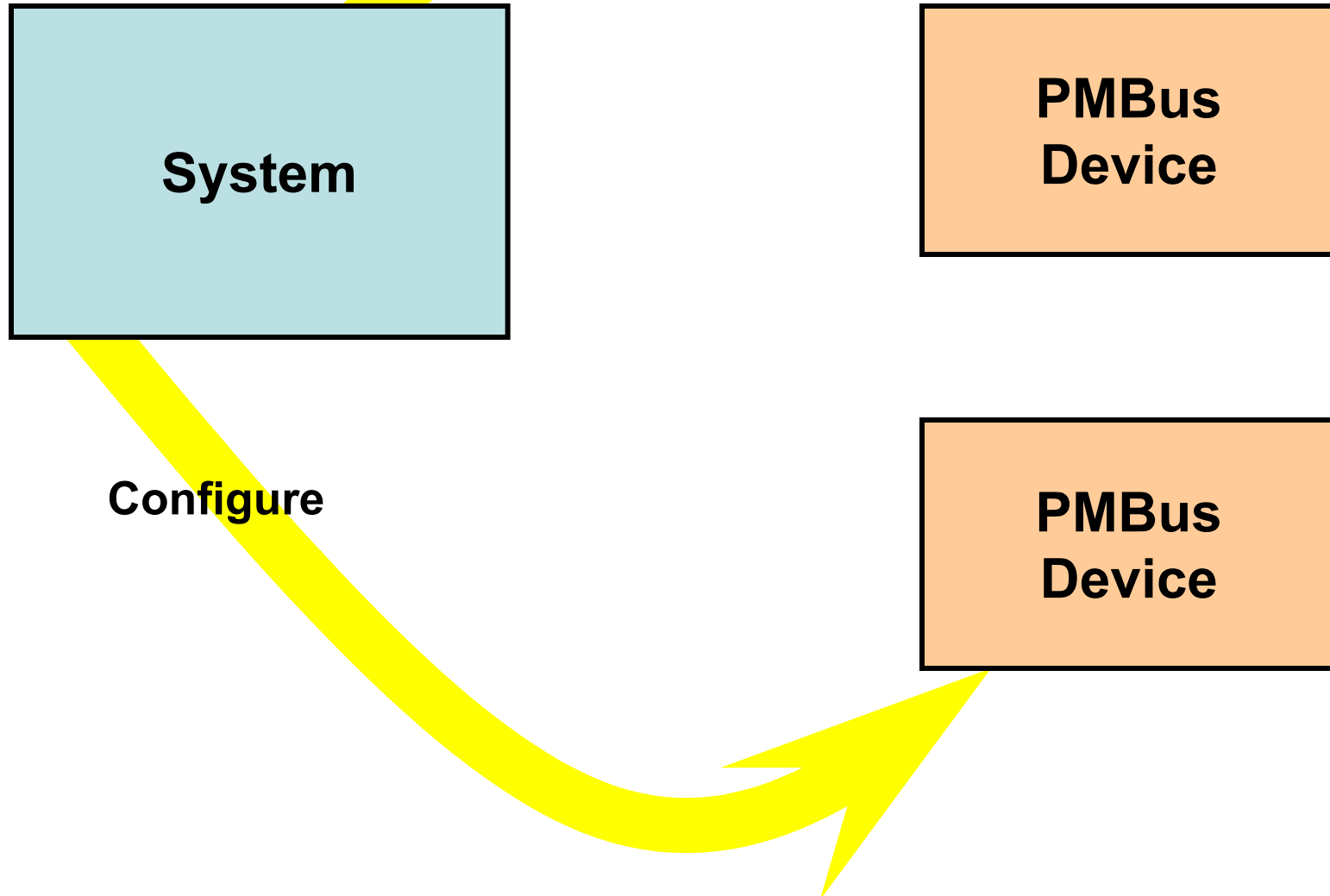

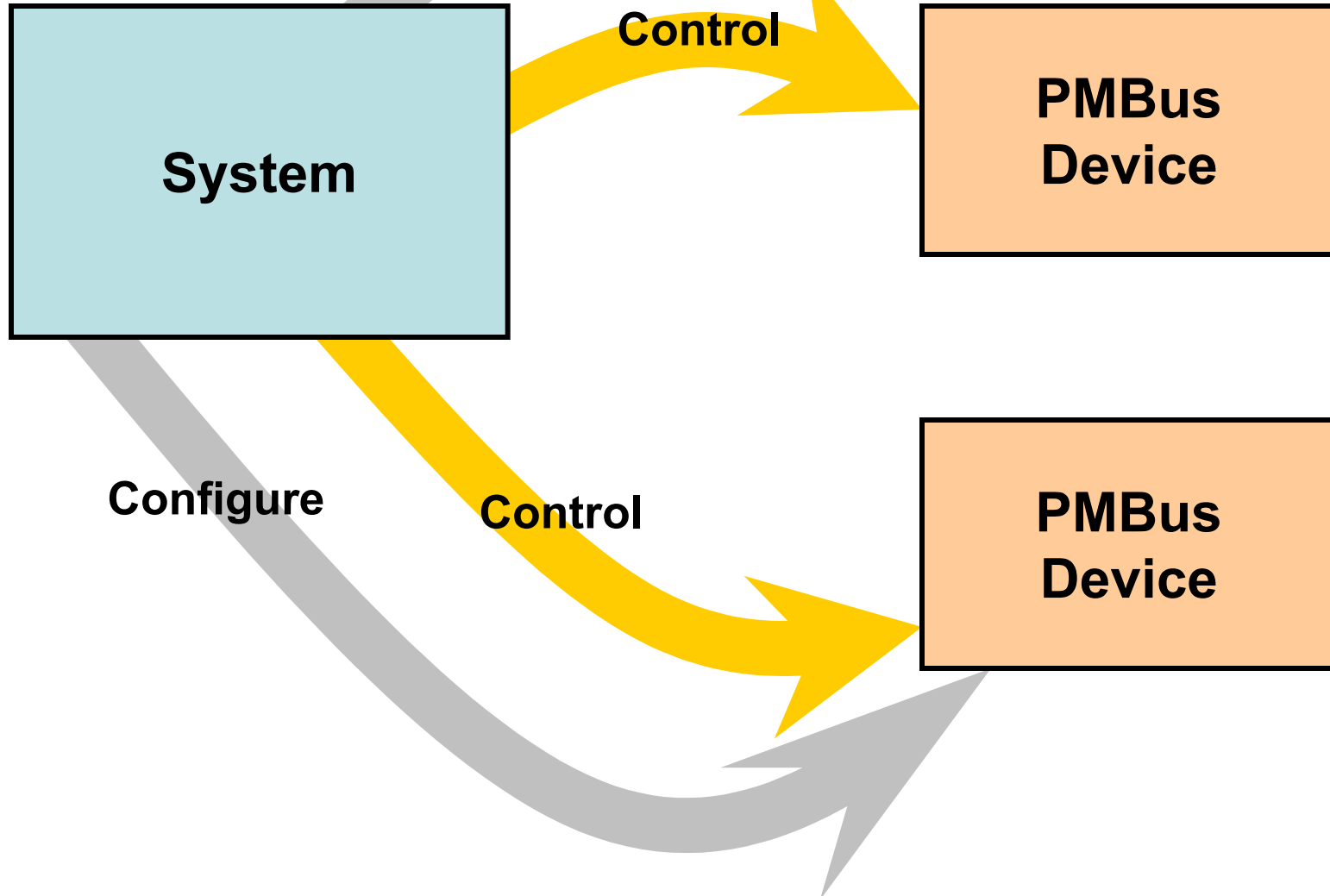

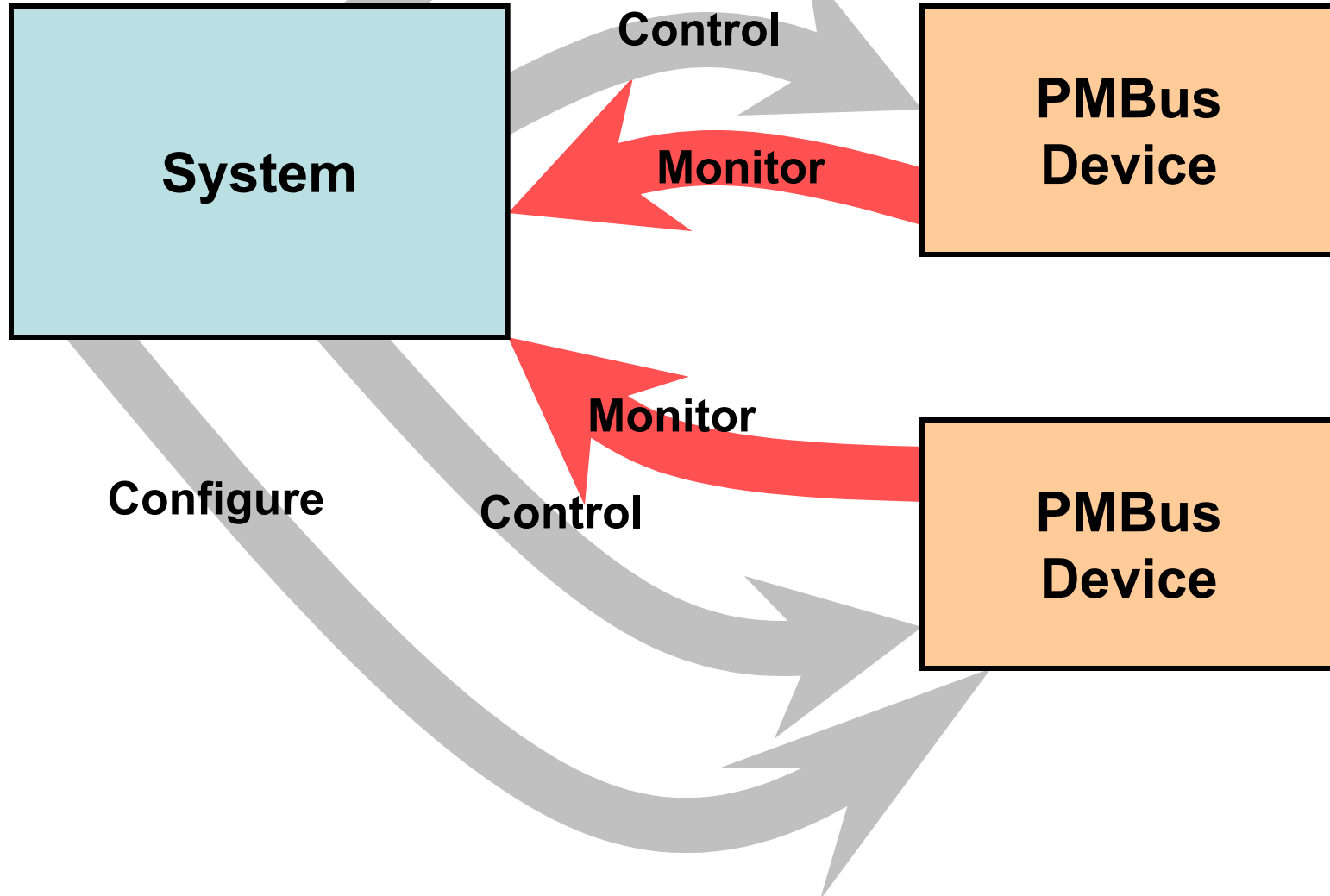

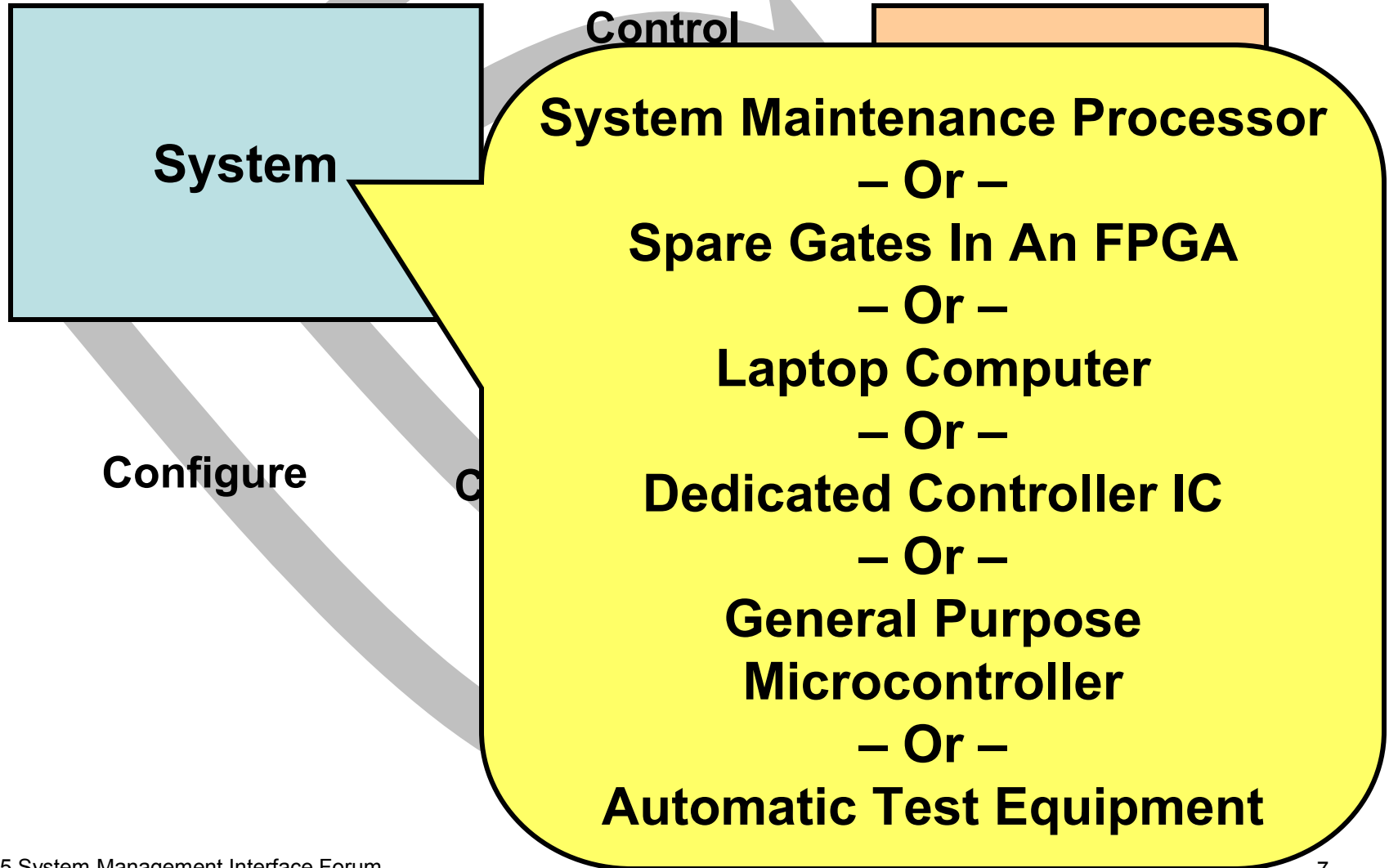

PMBus Is An Open Standard

- Owned By The System Management Interface Forum (SM-IF)
 - SM-IF Membership Is Open To All
- Royalty Free
- Released Specifications Freely Available
- Works With All Types Of Power Converters
 - AC-DC Power Supplies
 - Isolated DC-DC And Bus Converters
 - Non-Isolated Point-Of-Load Converters
 - Microprocessor Power Converters

PMBus: What It Is Not

- Not A Standard For A Power Supplies Or DC-DC Converters
 - No Form Factor, Pin Out, Efficiency, Etc.
 - Alliances Like POLA And DOSA Will Define
- No Converter-To-Converter Communication
 - Such As Current Share And Analog Voltage Tracking
 - Left To The IC And Power Supply Manufacturers
 - Including These Would Inhibit Future Innovation

Some Basic PMBus Requirements

- PMBus Devices Must Start Up Safely Without Bus Communication
- PMBus Devices Can Be Used With Or Without A Power System Manager/Controller
- PMBus Devices Support “Set And Forget”
 - Can Be Programmed Once At Time Of Manufacture
 - Then Operate Forevermore Without Bus Communication
- Defaults From Either/Or
 - Non-Volatile Memory
 - Pin Programming

Who Is PMBus?

PMBus Founders And Supporters

Founders

Artesyn Technologies

Emerson/Astec

Texas Instruments

Intersil

Microchip Technology

Summit Microelectronics

Volterra Semiconductor

Zilker Labs

Supporters



System Management Interface Forum, Inc.

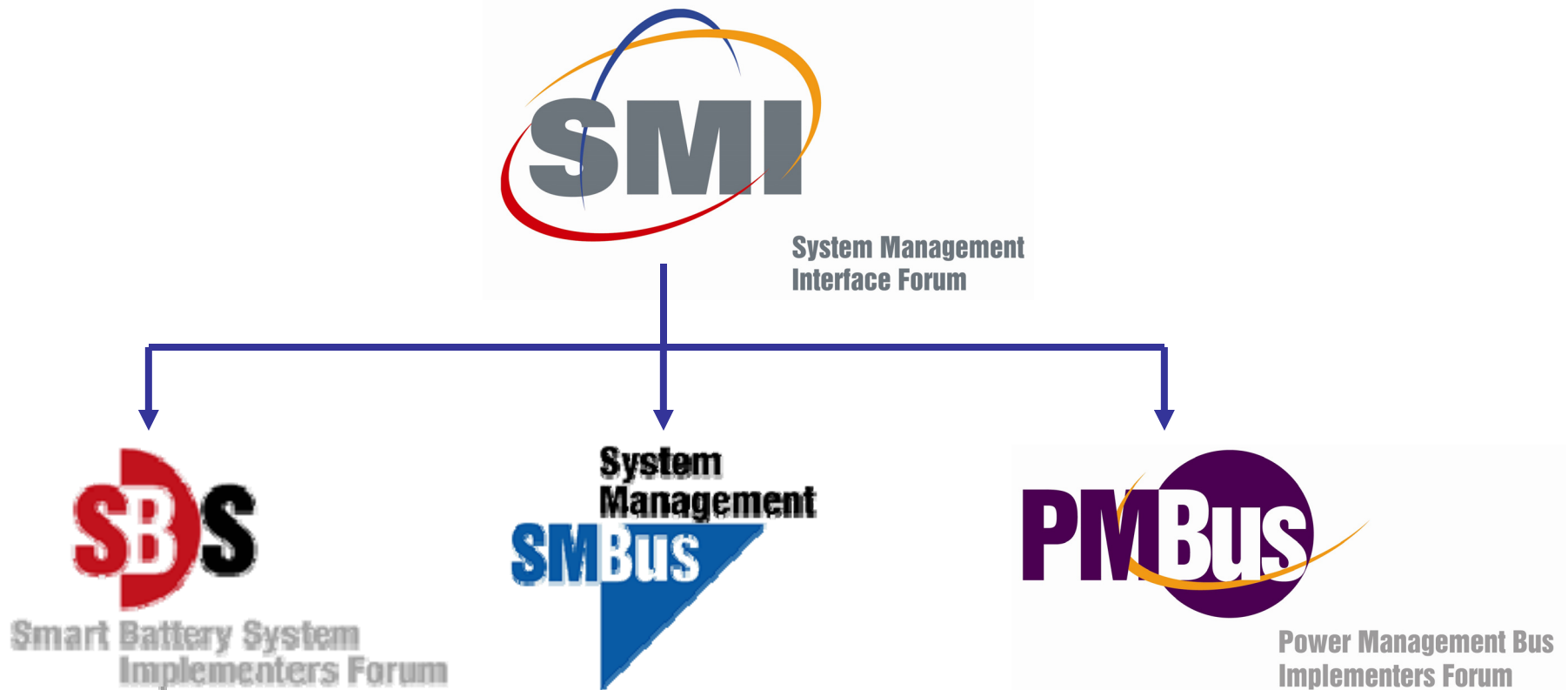

System Management Interface Forum, Inc.

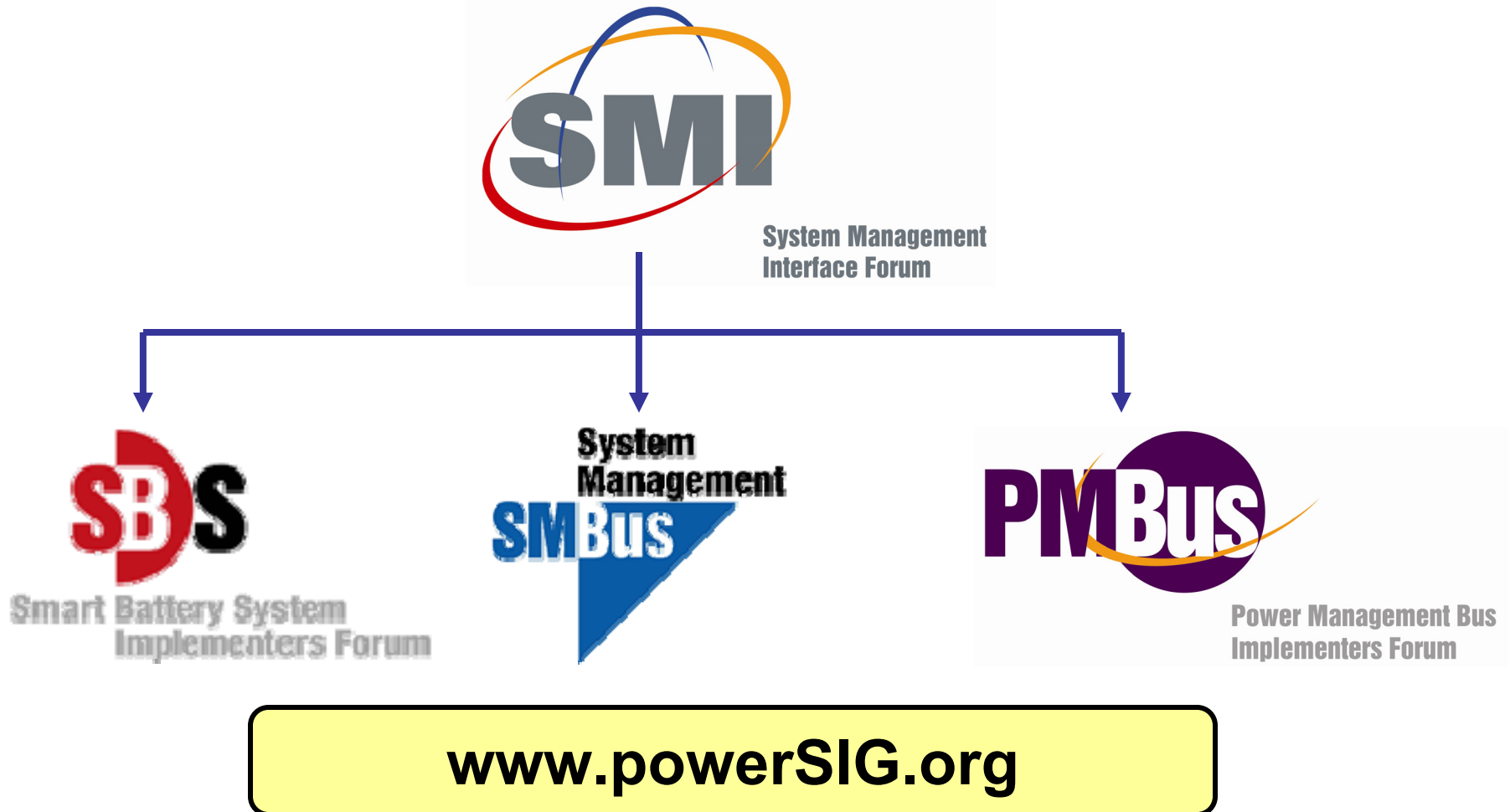

System Management Interface Forum, Inc.



**SM-IF Membership
Open To Any And All**

System Management
Interface Forum

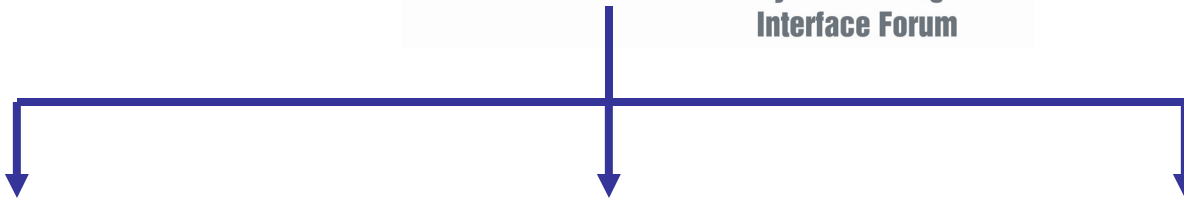

Smart Battery System
Implementers Forum



Power Management Bus
Implementers Forum

www.powerSIG.org

PMBus Specification

PMBus Specifications

- Part I: Transport
 - SMBus V1.1 Plus Extensions
 - Addressing
 - Hardwired Signals
 - Example: CONTROL Signal (On/Off Function)
- Part II: Command Language
 - Configuration
 - Control
 - Status Monitoring
 - Fault Management
 - Information Storage: Inventory, User Data, Etc.

Why SMBus?

- Low Cost Like I²C
- More Robust Than I²C
 - Timeouts Force Bus Reset
- More Features Than I²C
 - SMBALERT# Line For Interrupts
 - Packet Error Checking (PEC)
 - Host Notify Protocol
- Generally Electrically Compatible With I²C

Addressing I²C Shortcomings

- “Noise Sensitivity” – Edge Triggering
 - False START: Timeouts Force Reset
 - False STOP: PMBus Devices Detect Failed Transmissions As Faults
- “Noise Sensitivity” – Corrupt Data
 - Data Rates Permit Digital Filtering
 - Packet Error Checking (PEC)
 - Every Value That Can Be Written Can Be Read

Addressing I²C Shortcomings

- Slave Device Hangs Bus
 - Timeouts Force Device Reset
- Requires Retrieving Device Information By Polling
 - SMBALERT# Line Acts As An Interrupt
 - Automatic Bitwise Arbitration Of Simultaneous Requests
- No More Than 8 Devices Of A Type On One Bus
 - No Central Address Control Bureaucracy
 - Over 100 Device Addresses Available

Other Issues

- Fault Tolerance
 - Physically Failed Devices Are A Problem With Any Bus
 - Must Add Isolating Switches And Multiplexers
- 400 pF Maximum Bus Capacitance Requires Repeaters Or Bridges For:
 - Large Numbers Of Devices
 - Long Distance

PMBus™ Connections

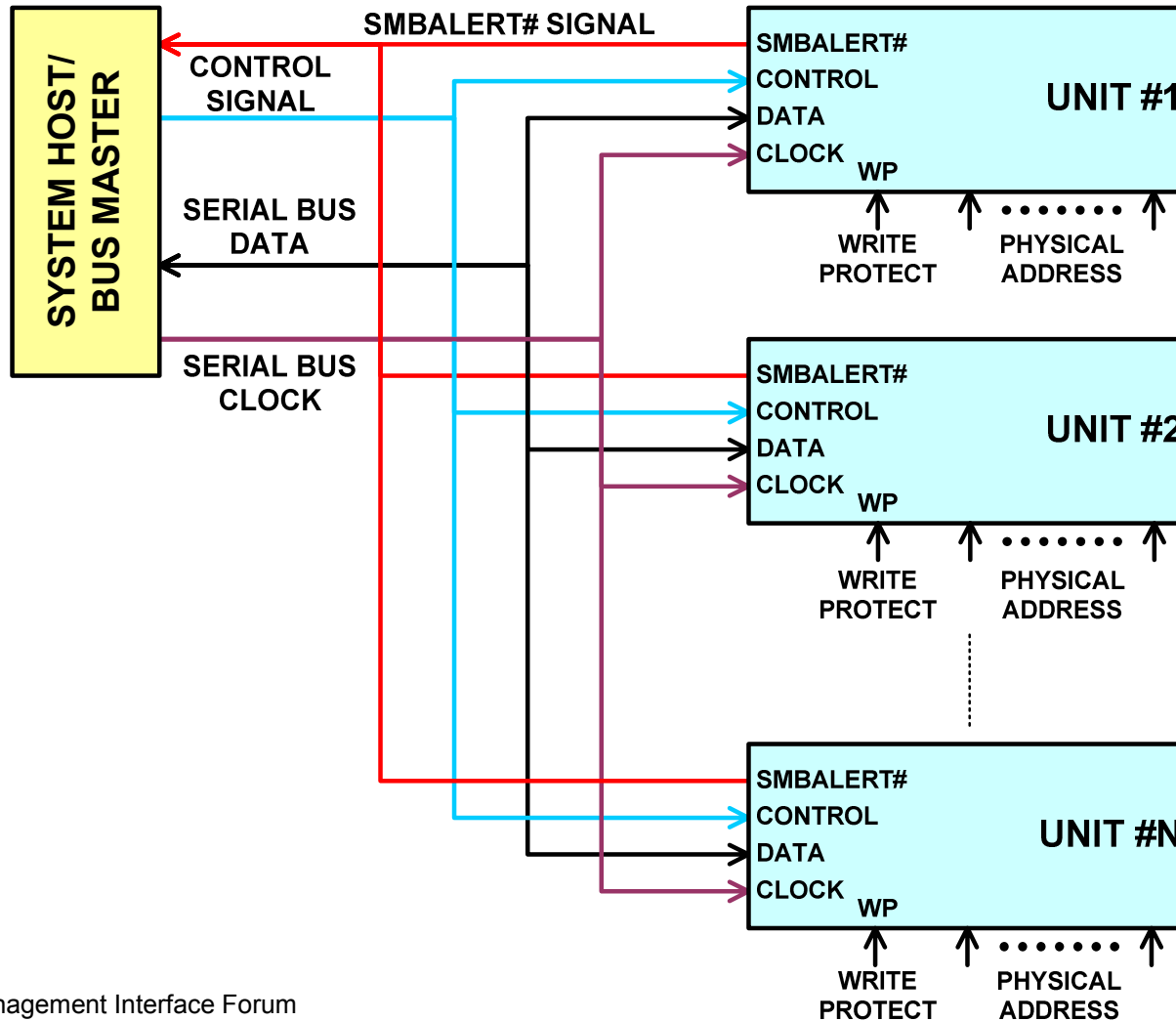

PMBus™ Connections

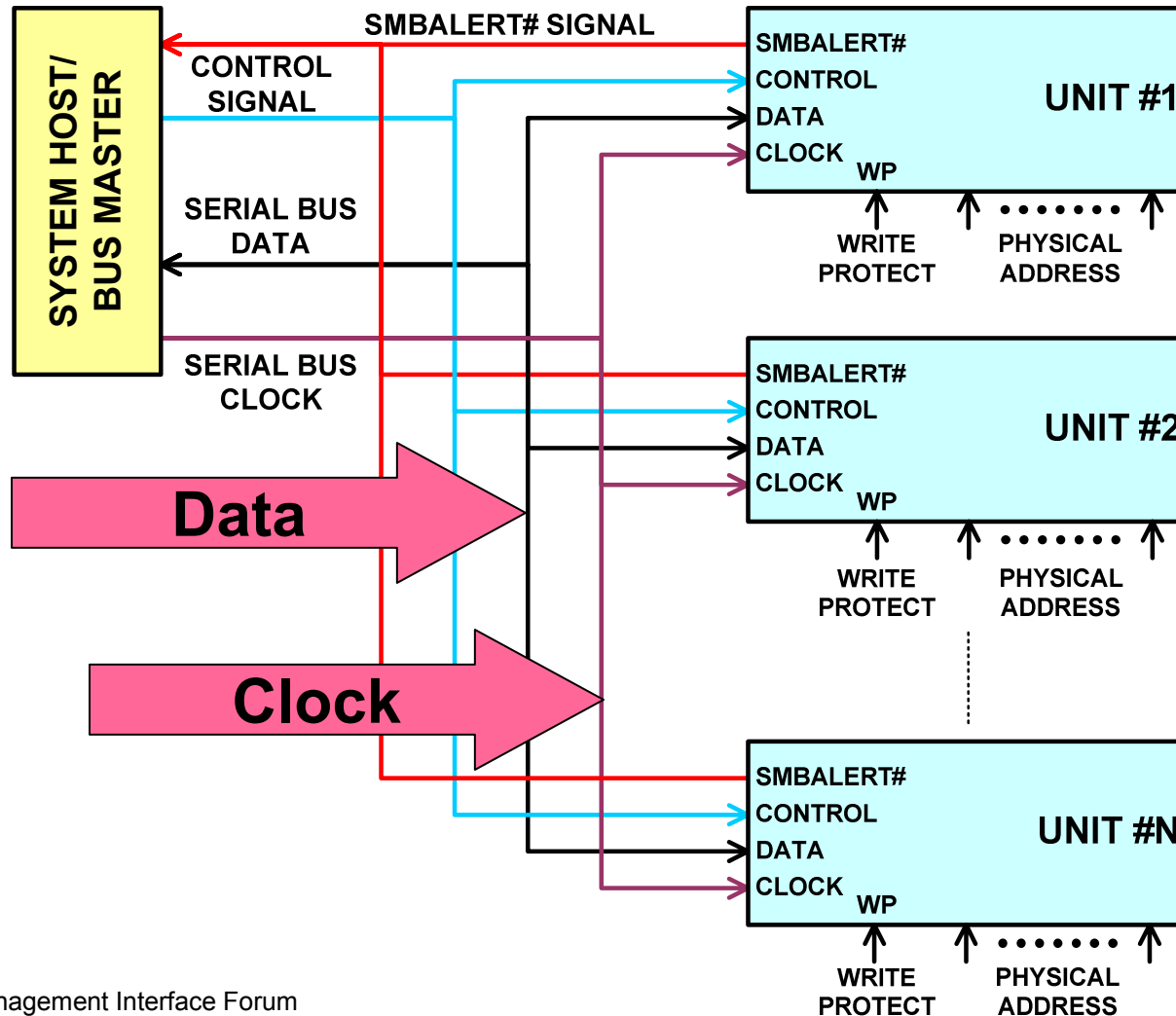

PMBus™ Connections

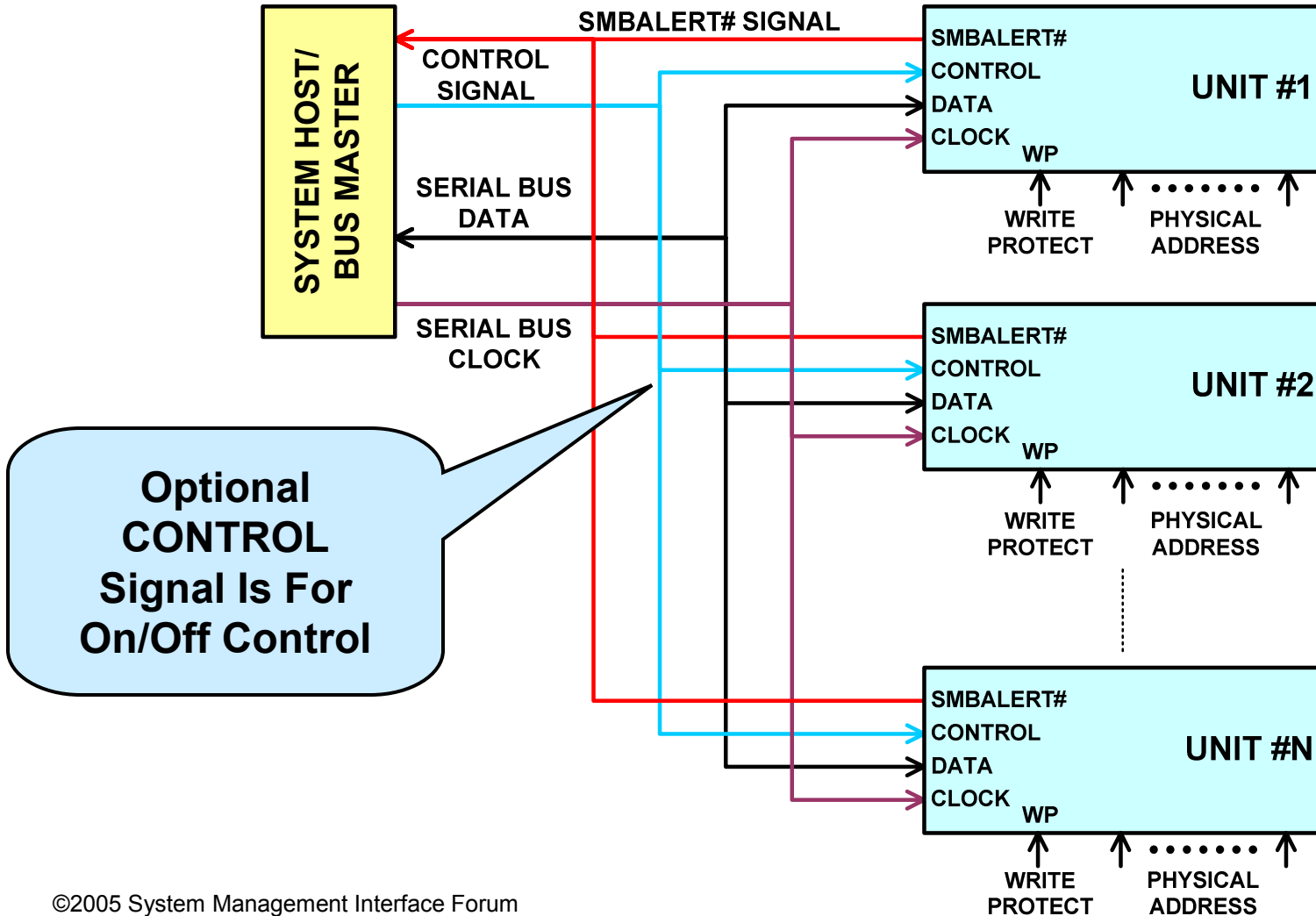

PMBus™ Connections

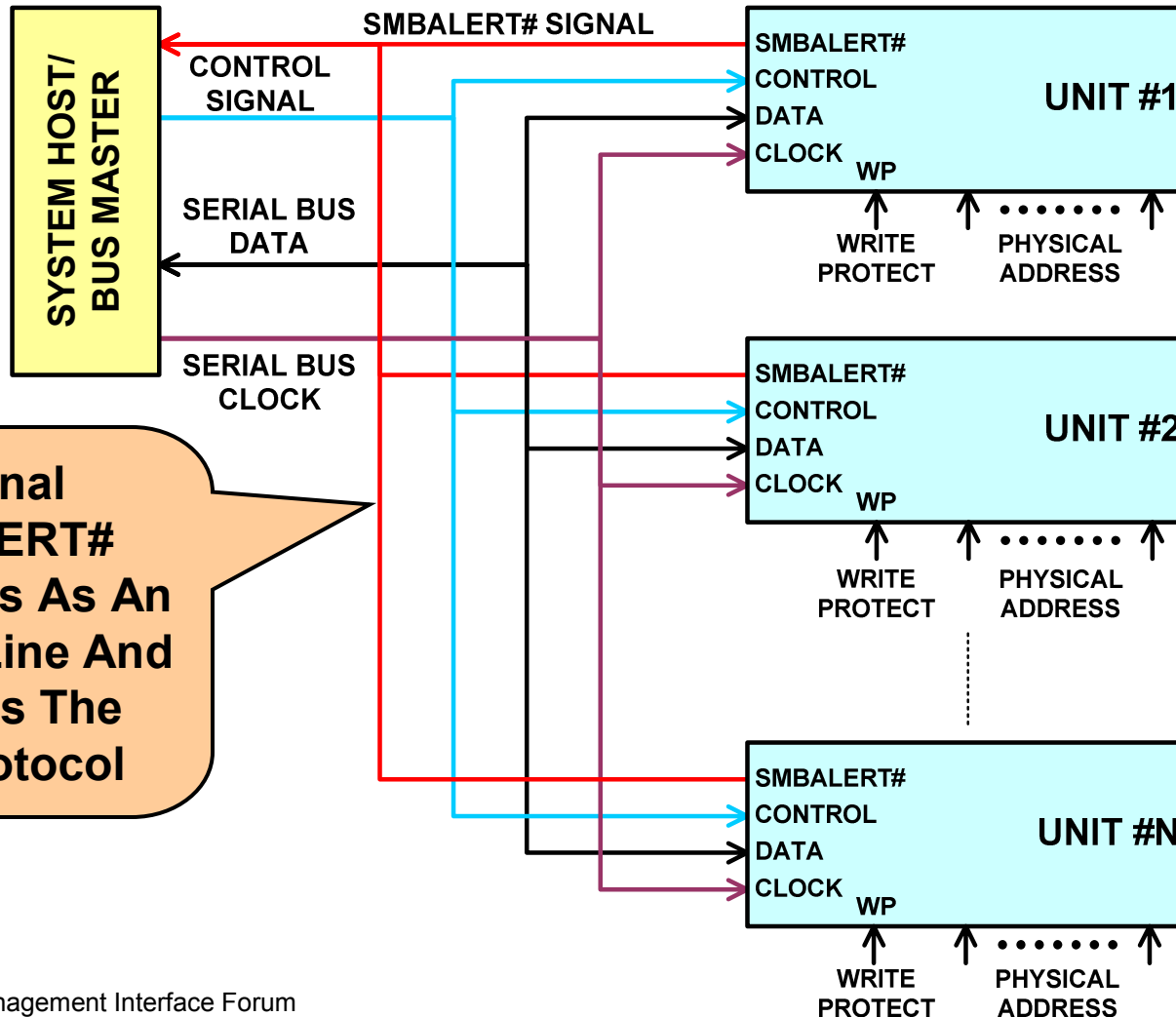

Optional SMBALERT# Signal Acts As An Interrupt Line And Activates The Alert Protocol

PMBus™ Connections

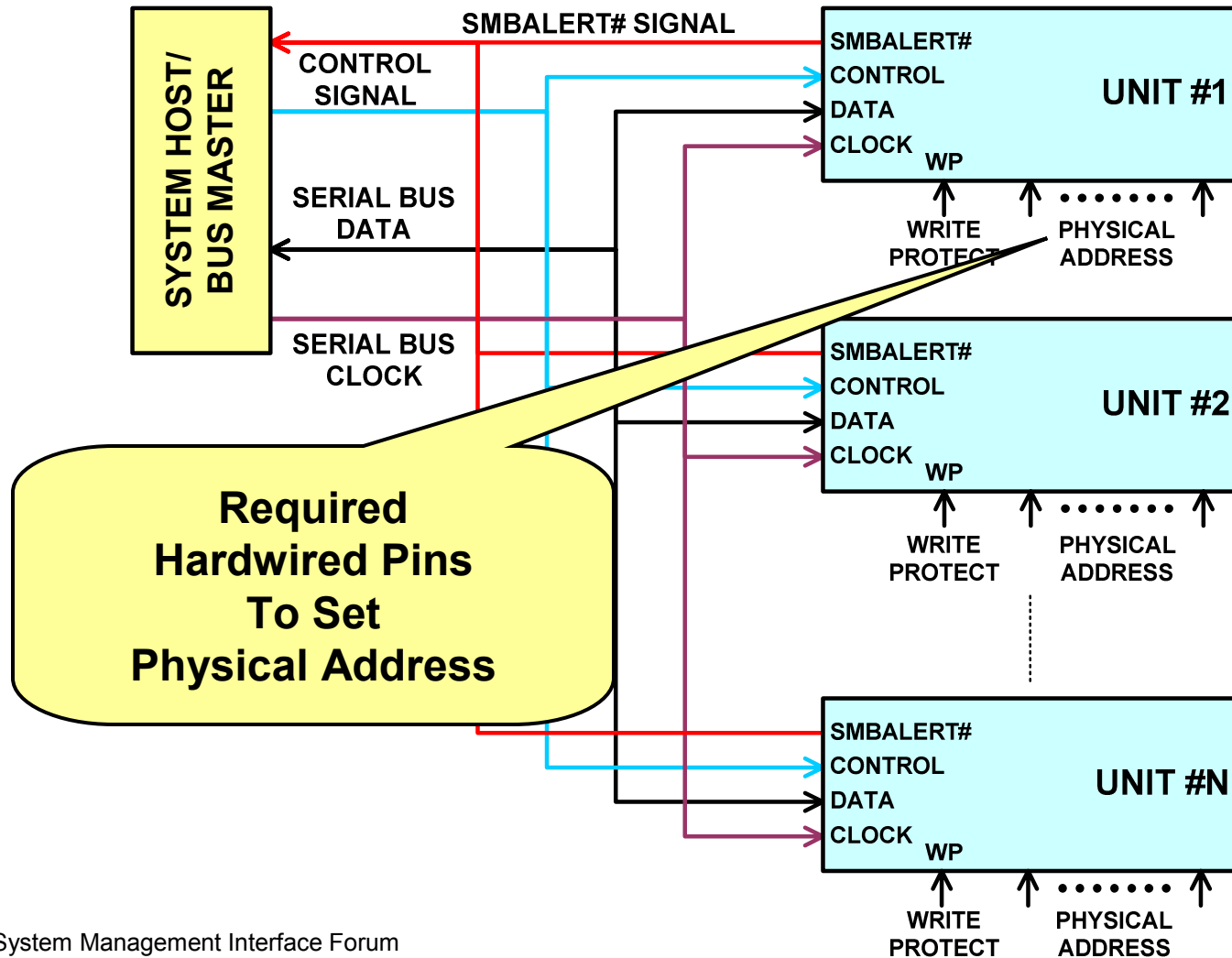

PMBus™ Connections

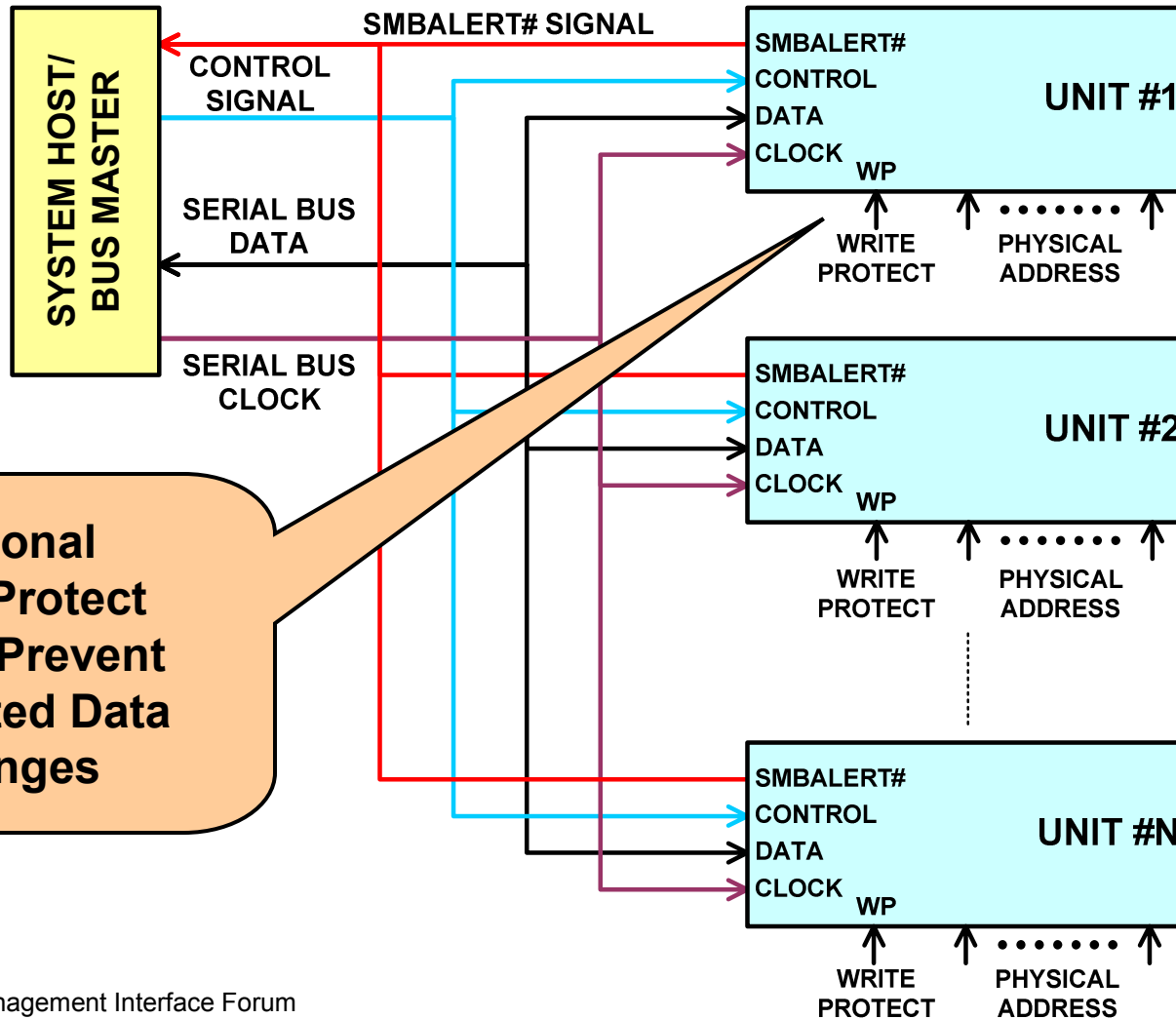

PMBus™ In A Large System

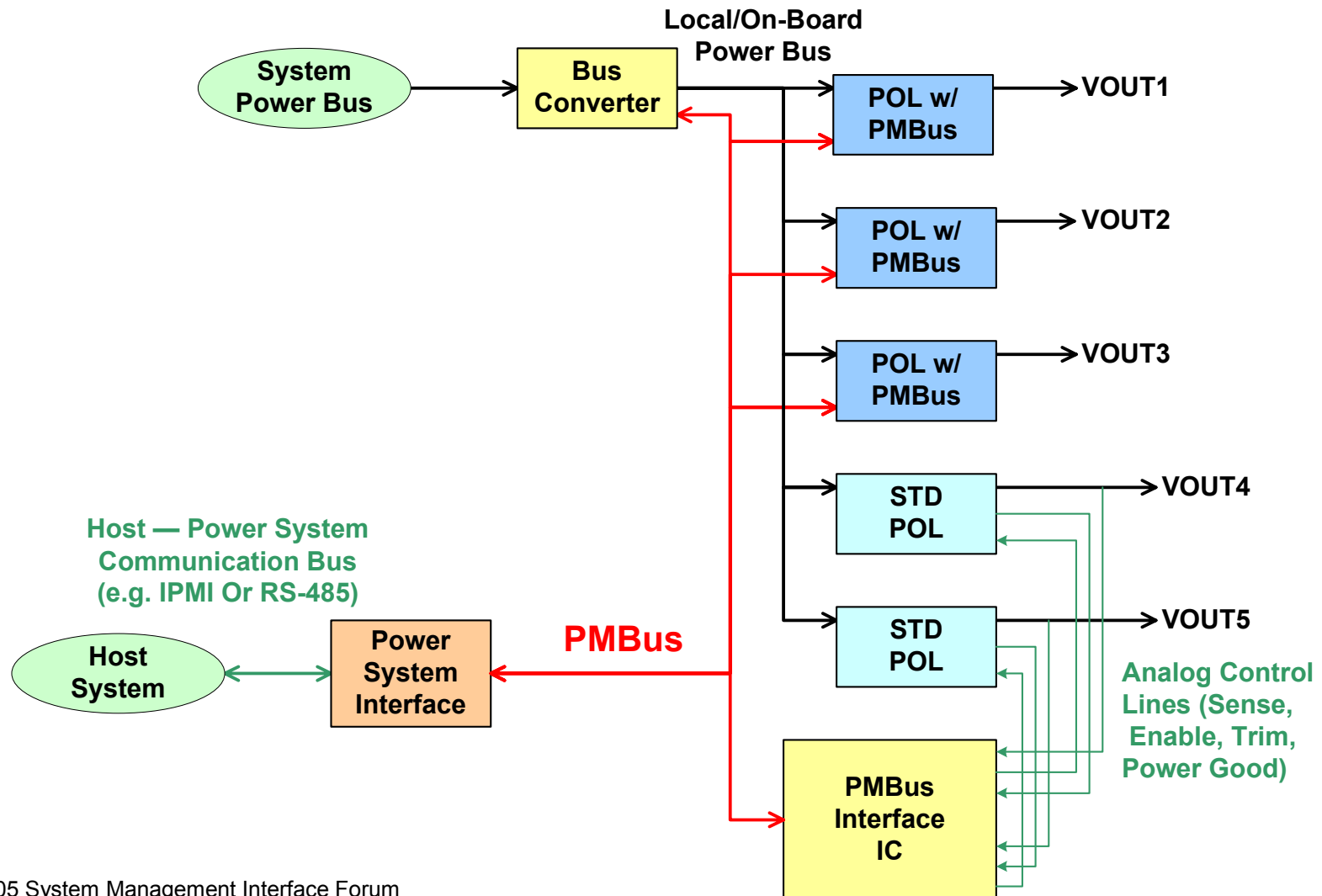

PMBus™ In A Large System

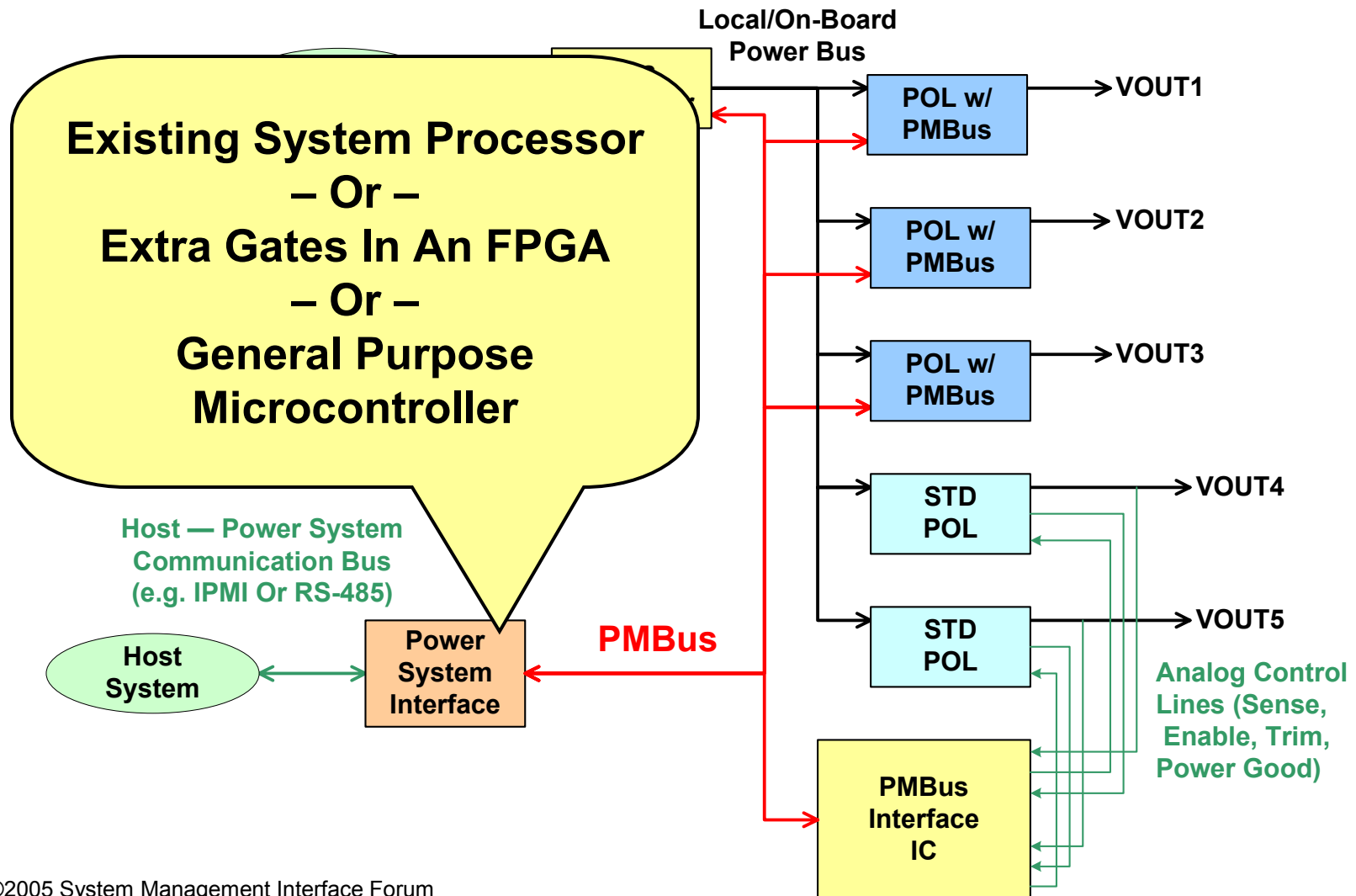

Typical Packet Structure

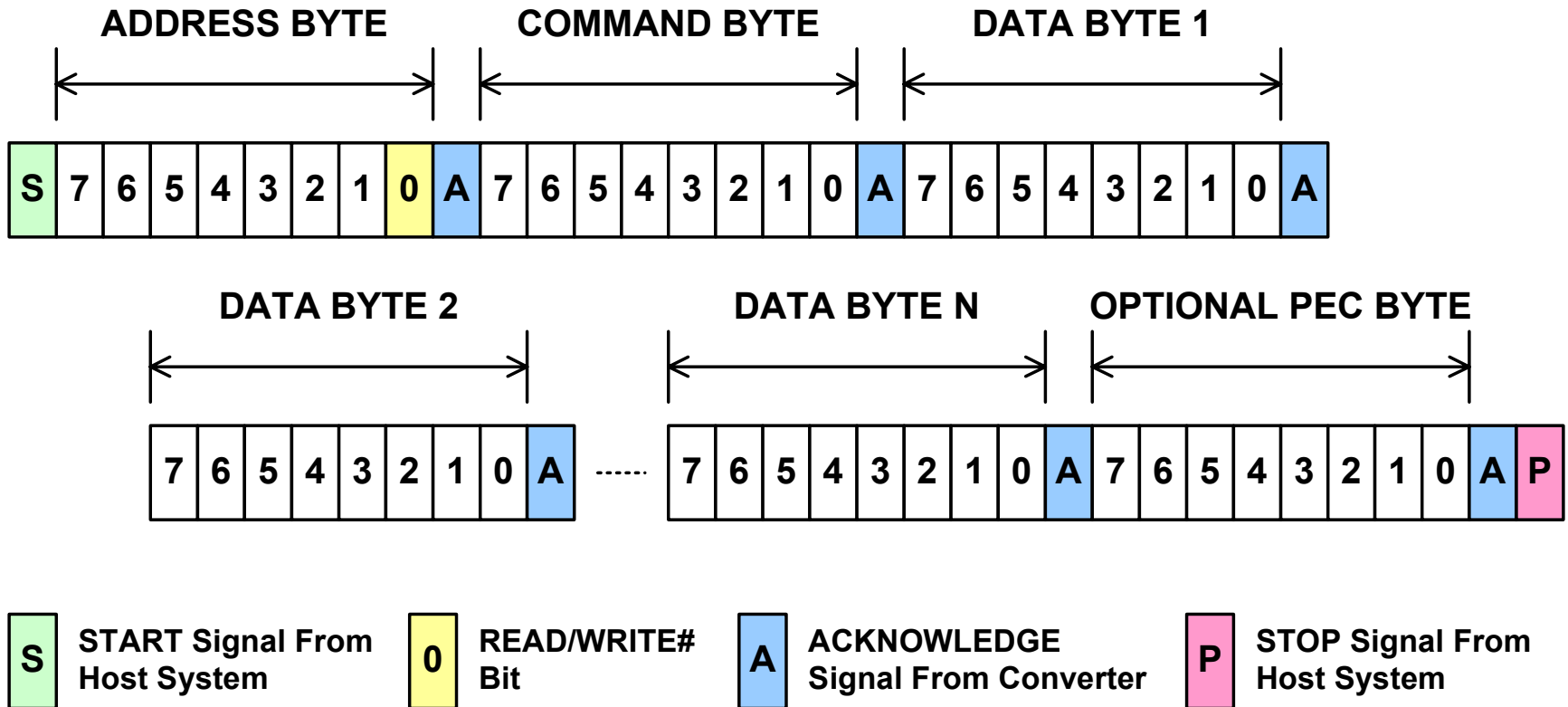

Addressing

- PMBus Devices Use A 7 Bit Address Per The SMBus Specification
 - Provides More Than 100 Possible Device Addresses After Allowing For Reserved Addresses
- No I²C Style Address Control Assignments Or Limitations
- PMBus Users Can Expect Device Addresses To Be Set By A Mix Of:
 - Hardwired Address Pins
 - High Order Address Bits Set By The PMBus Device Manufacturer

Addressing (cont'd)

- PMBus Device Manufacturers Will Trade Off Cost Of Pins Versus Address Flexibility
- Expect Device Makers To Offer Tri-State Pins Or Resistor Value Programming
- Examples Of The Possibilities
 - 3 Tri-State Pins => 27 Addresses
 - 1 Resistor Programmed Pin => 16–32 Addresses

Multiple Output Units And Paging

- Paging Allows One Physical Address To Be Used To Control Multiple Outputs
 - One Address Per Physical Unit
 - One Page Per Output
 - Pages Contain All The Settings Of Each Output
- Paging Process
 - Set Page For Output Of Interest
 - Send Commands
 - Configure, Control, Read Status

Paging: Multiple Output Units

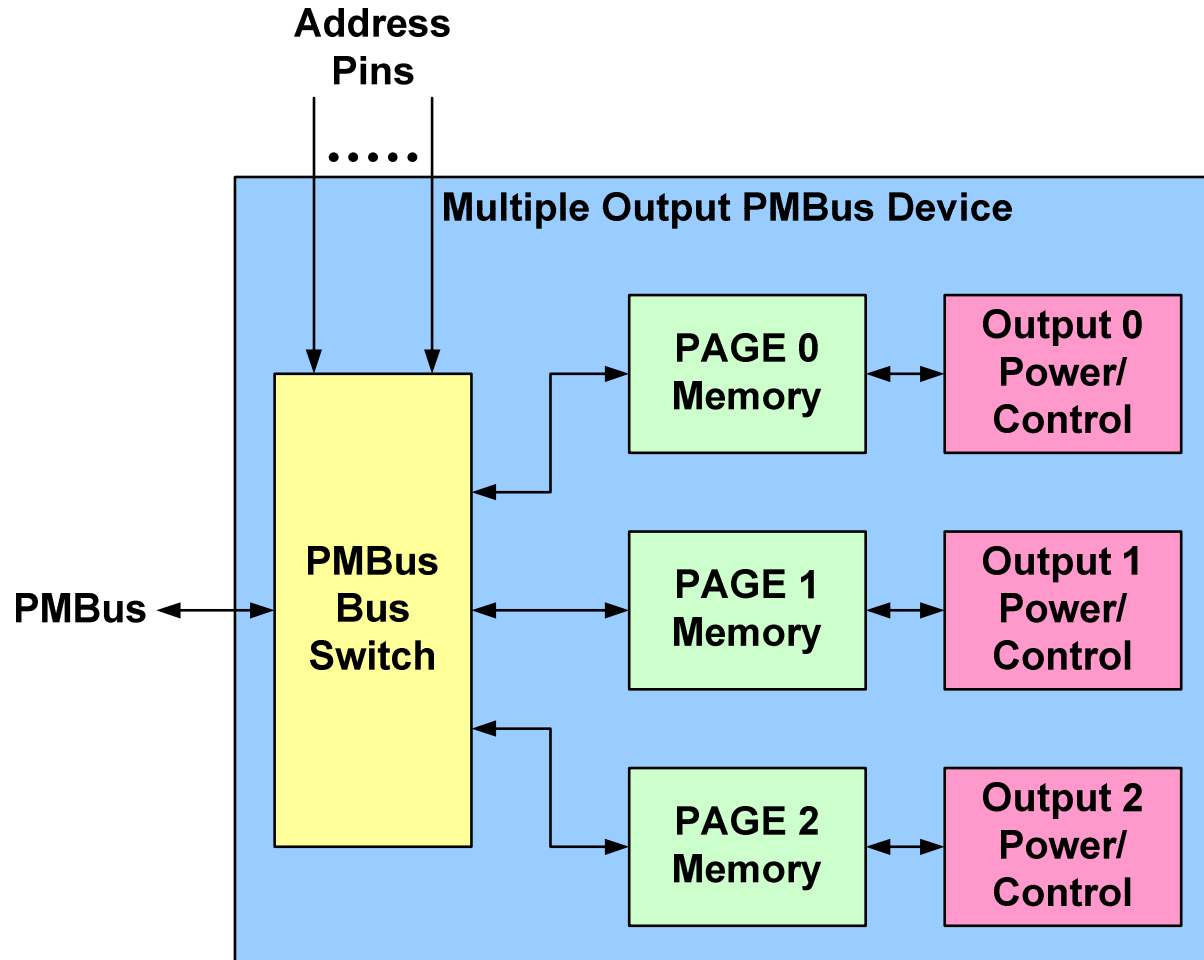

Paging: Non-PMBus Device Adapter

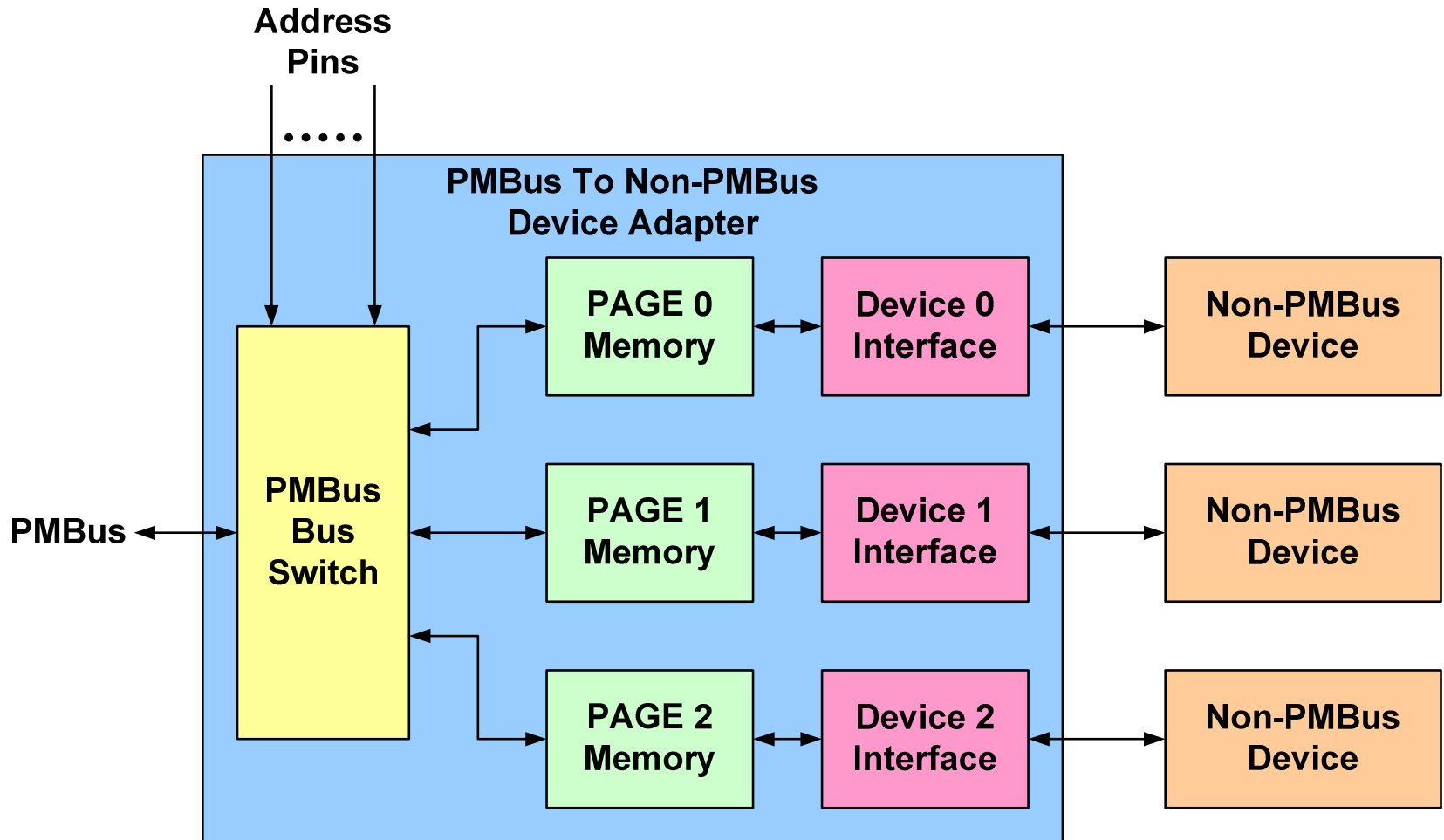

Paging: Non-PMBus Device Adapter

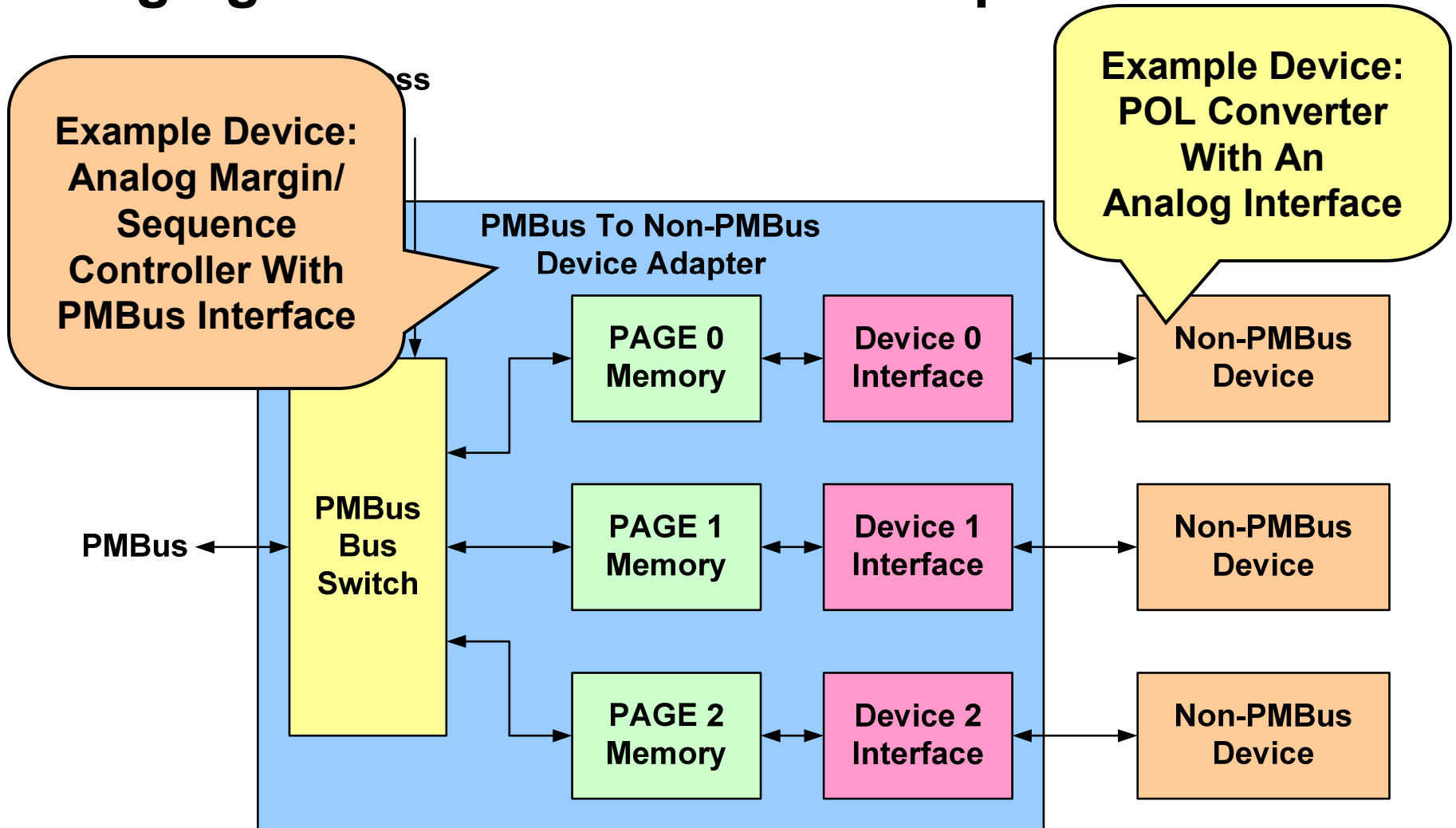

Command Language

- Extensive And Comprehensive
- Commands Take Effect Immediately
- Every Value That Can Be Written
Can Be Read

Command Language

- Extensive And Comprehensive
- Commands Take Effect Immediately
- Every Value That Can Be Written
Can Be Read

Not All Devices Support All Commands!

**Devices Will Support Commands Appropriate
To Their Intended Application
And Price Point**

Concept: Setting The Output Voltage

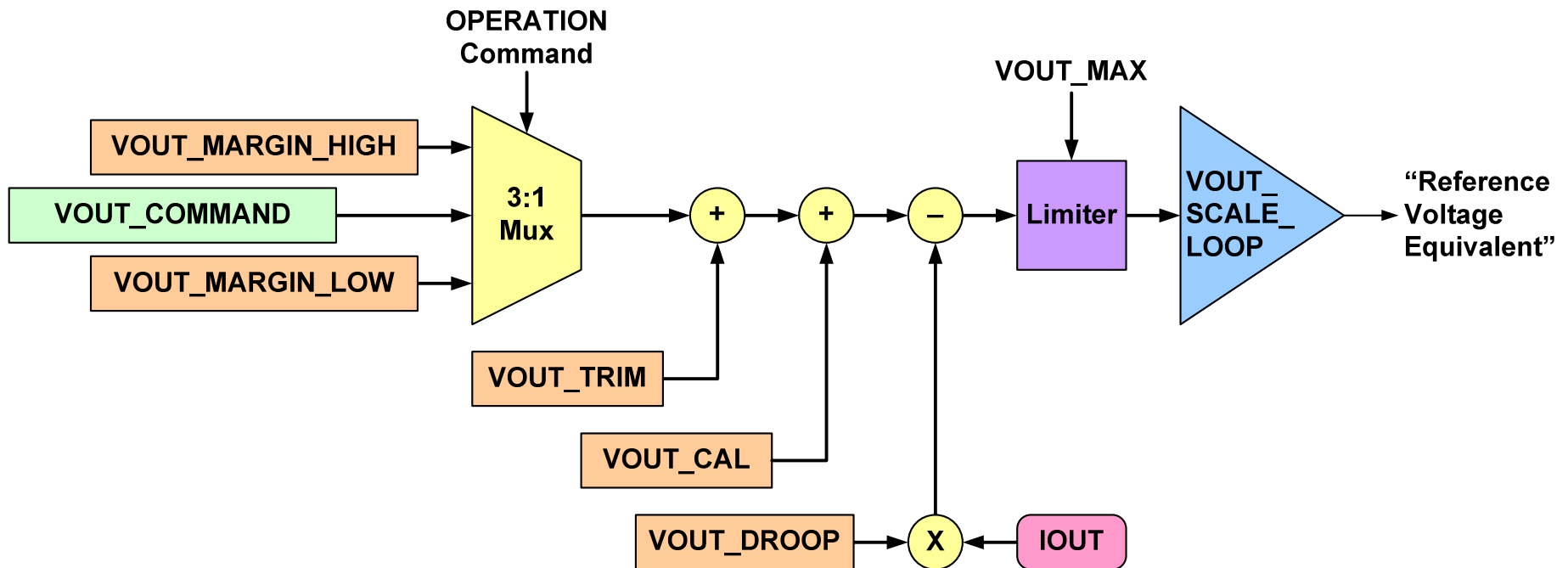

Memory And Startup Concepts

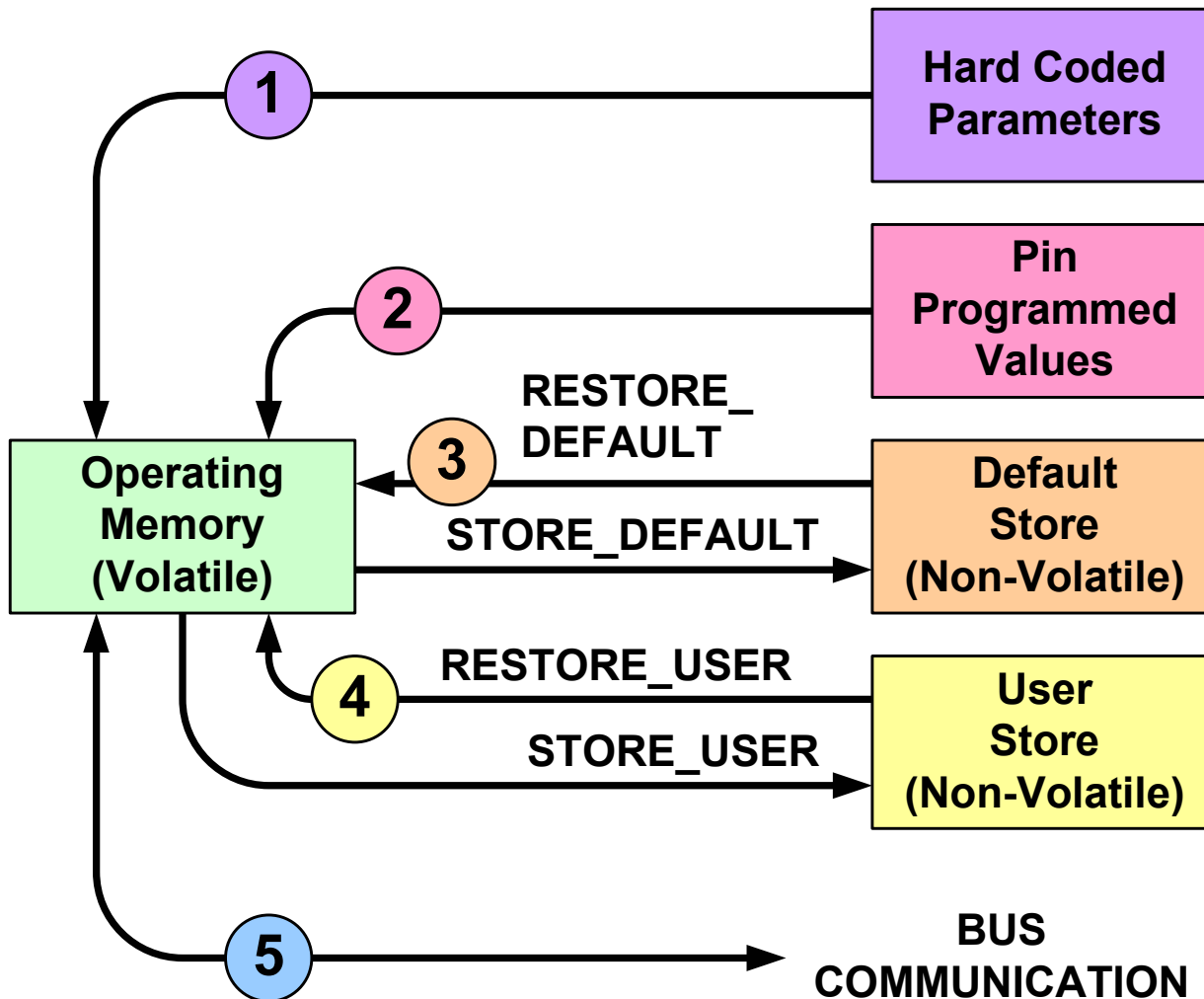

Memory And Startup Concepts

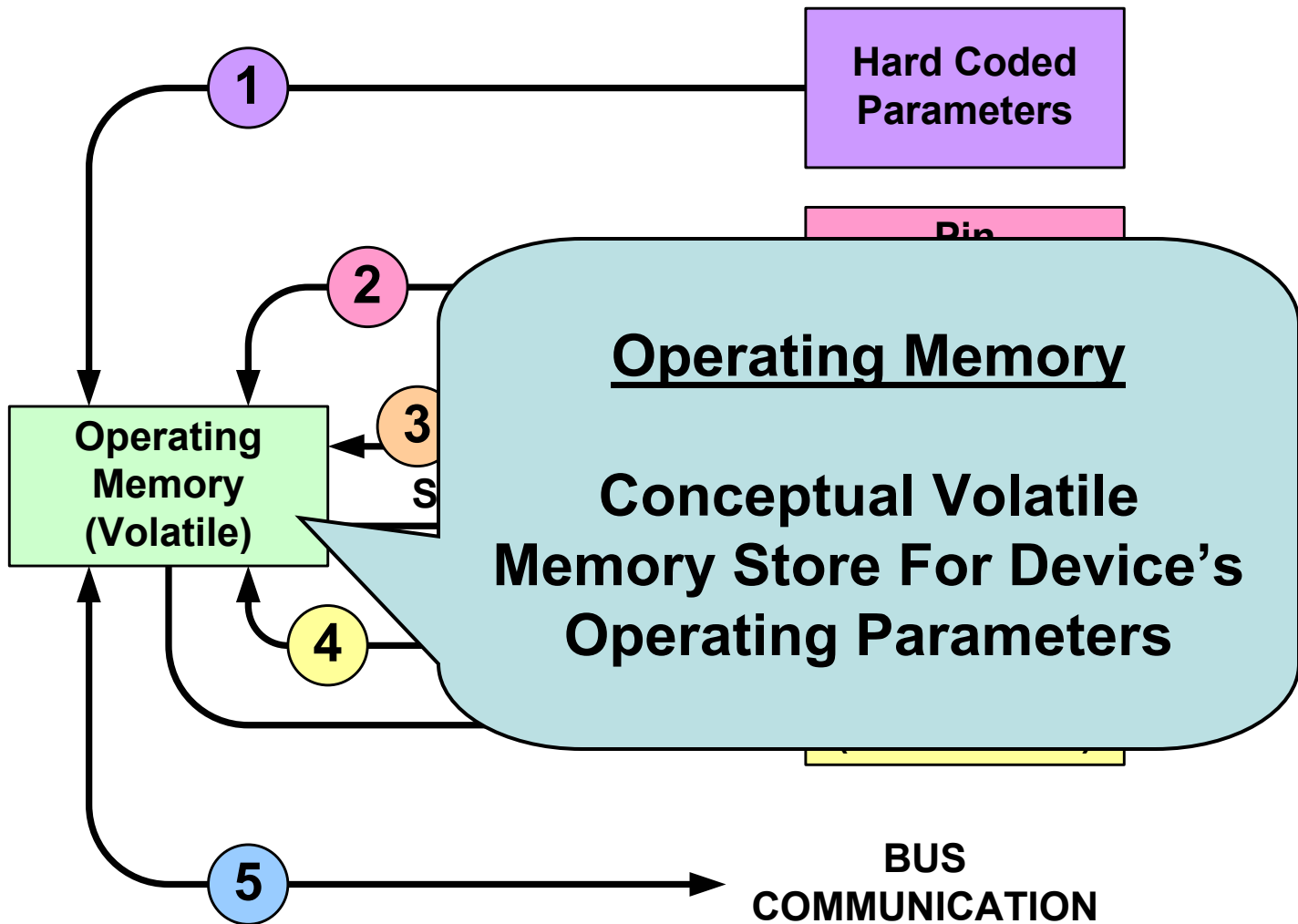

Memory And Startup Concepts

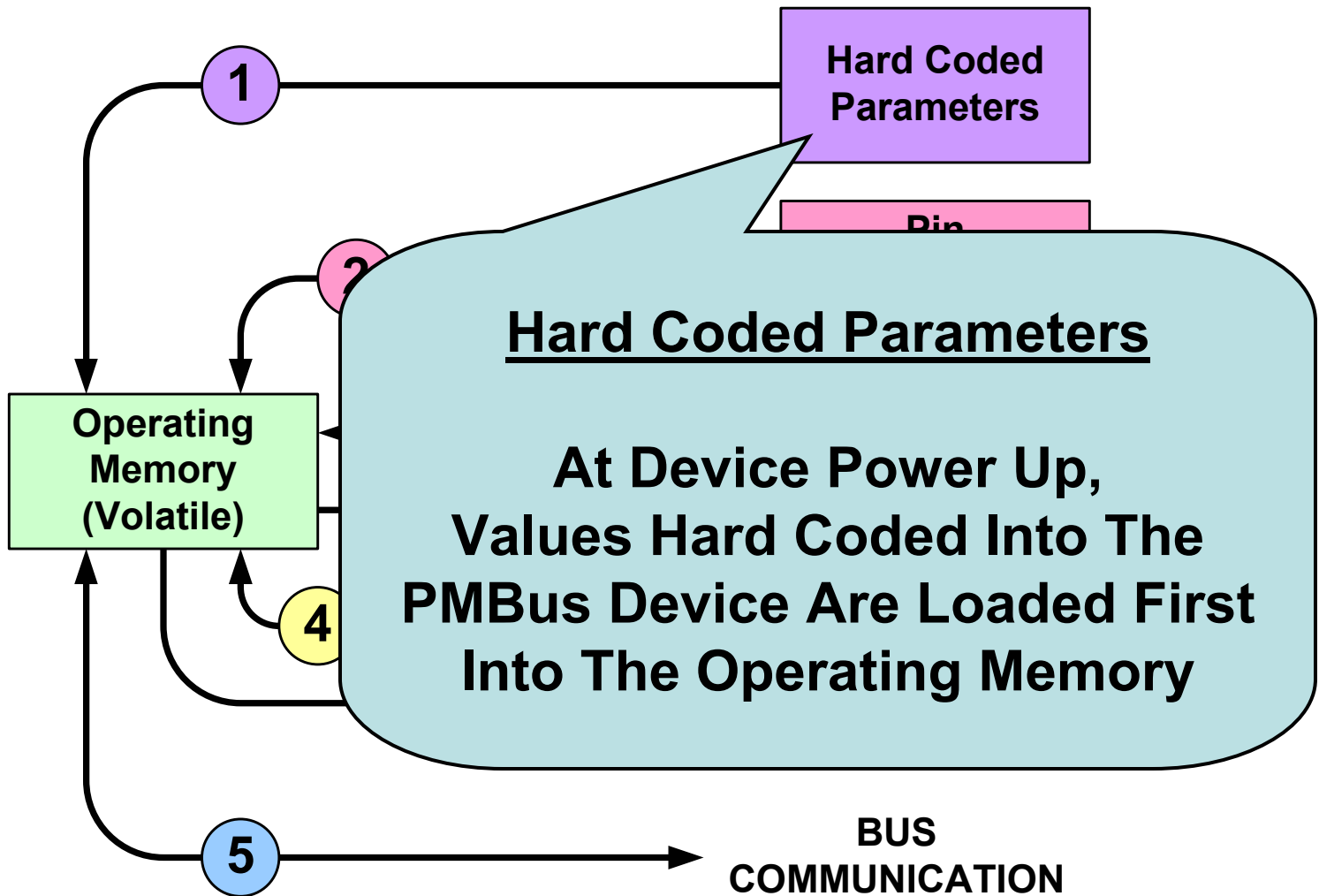

Memory And Startup Concepts

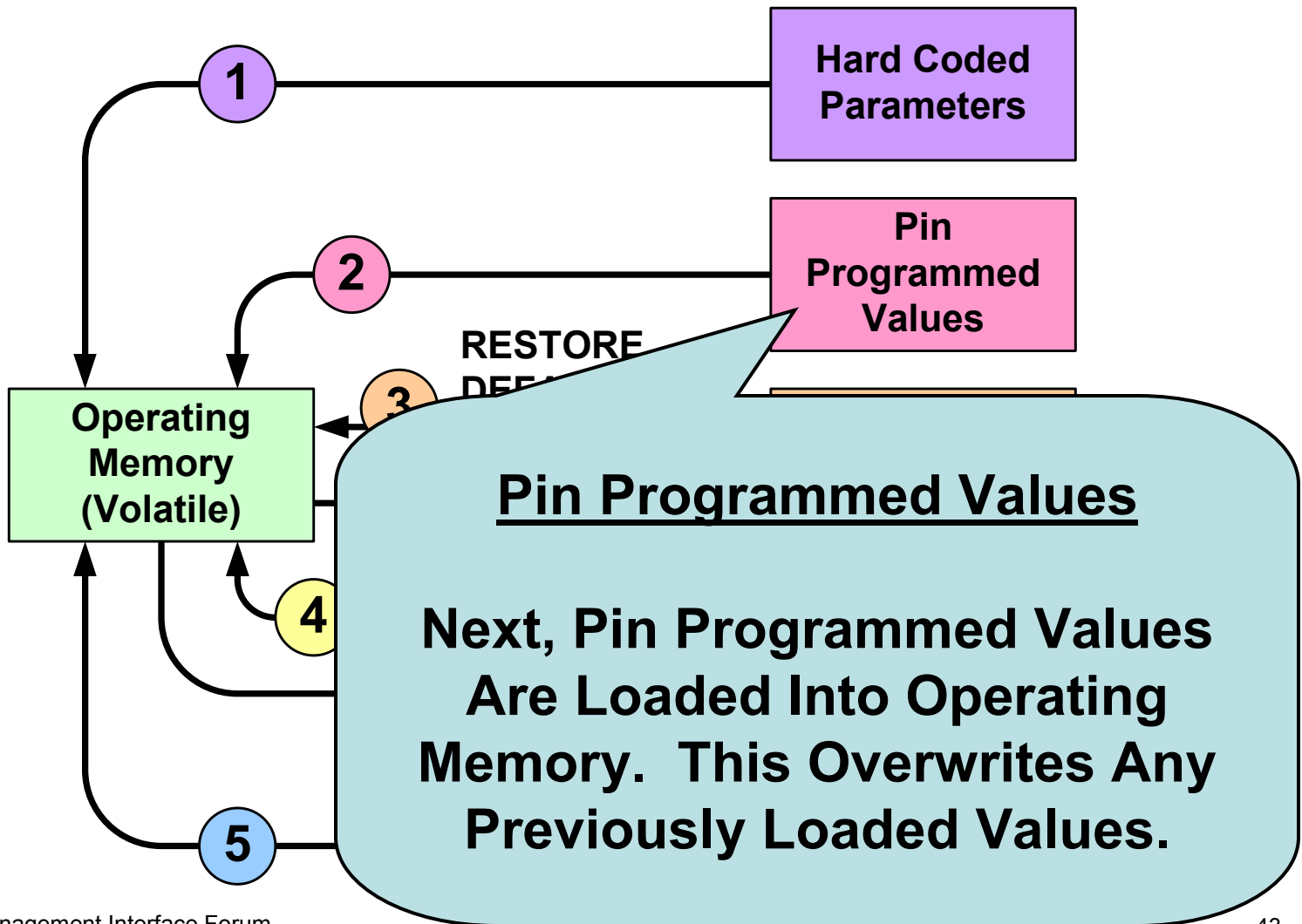

Memory And Startup Concepts

Default Values

Next, Values From The Non-Volatile Default Store (If Provided) Are Loaded. This Overwrites Any Previously Loaded Values.

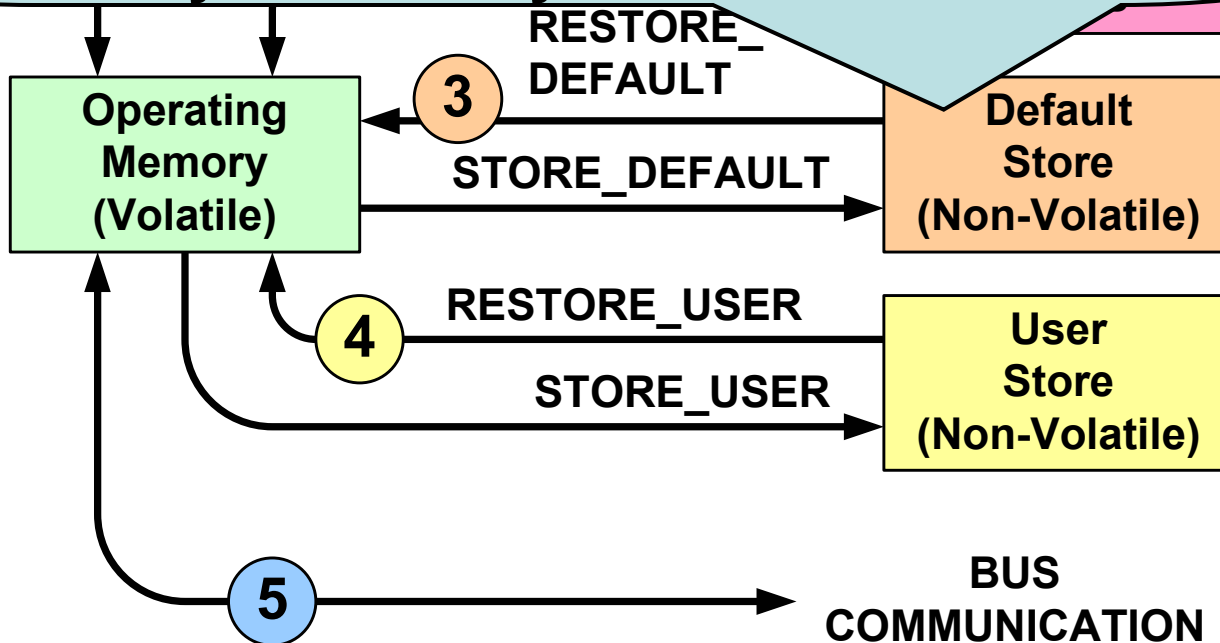

Memory And Startup Concepts

User Stored Values

Next, Values From The Non-Volatile User Store (If Provided) Are Loaded. This Overwrites Any Previously Loaded Values.

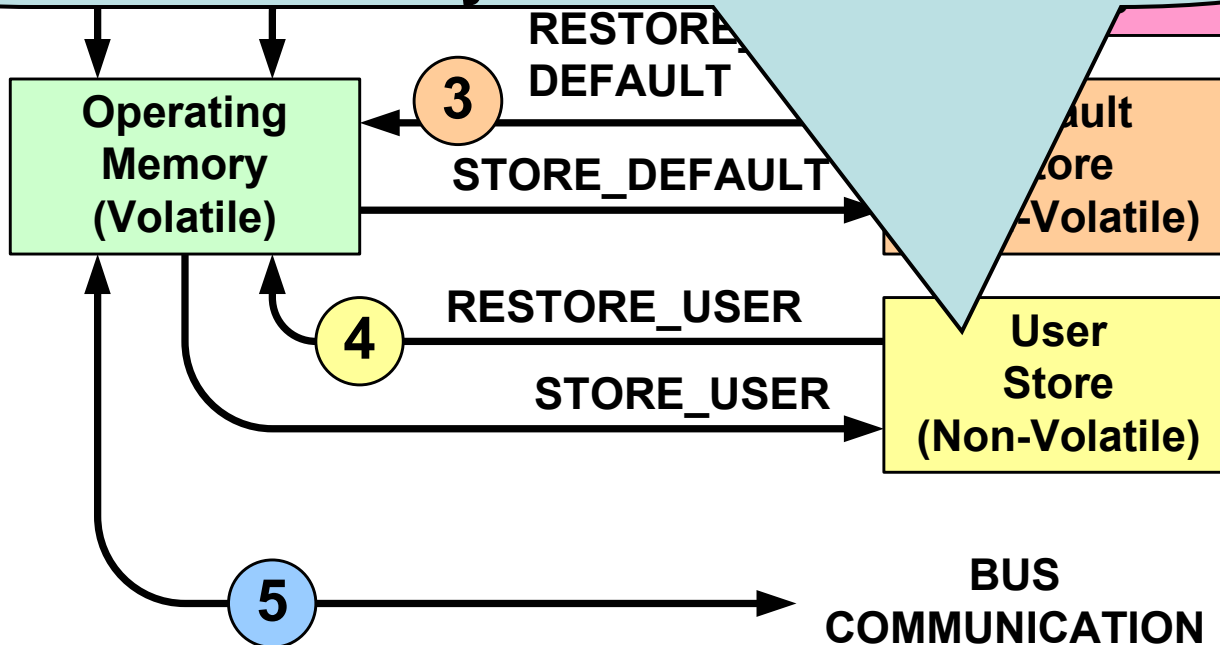

Memory And Startup Concepts

Bus Communication

Next, Values Sent Via The SMBus Are Loaded.
This Overwrites Any Previously Loaded Values.

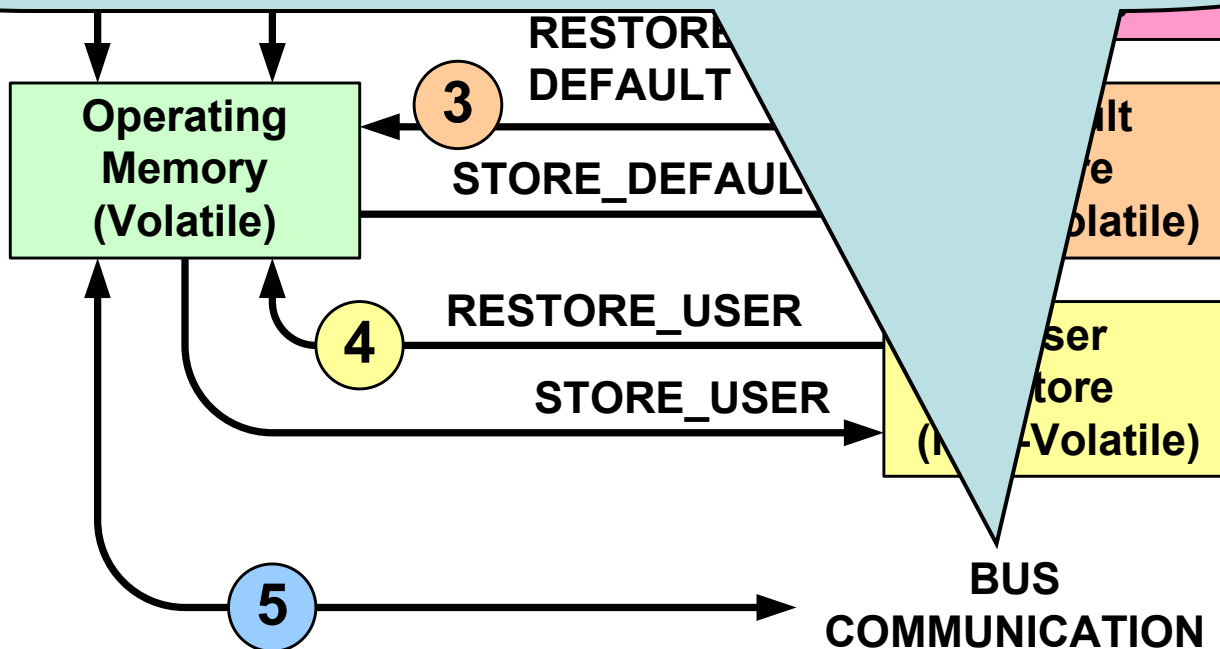

Memory And Startup Concepts

Used To Store A Snapshot Of The Device's Operating State. When Power Removed And Restored, Device Can Resume Operation From Its Last Programmed State.

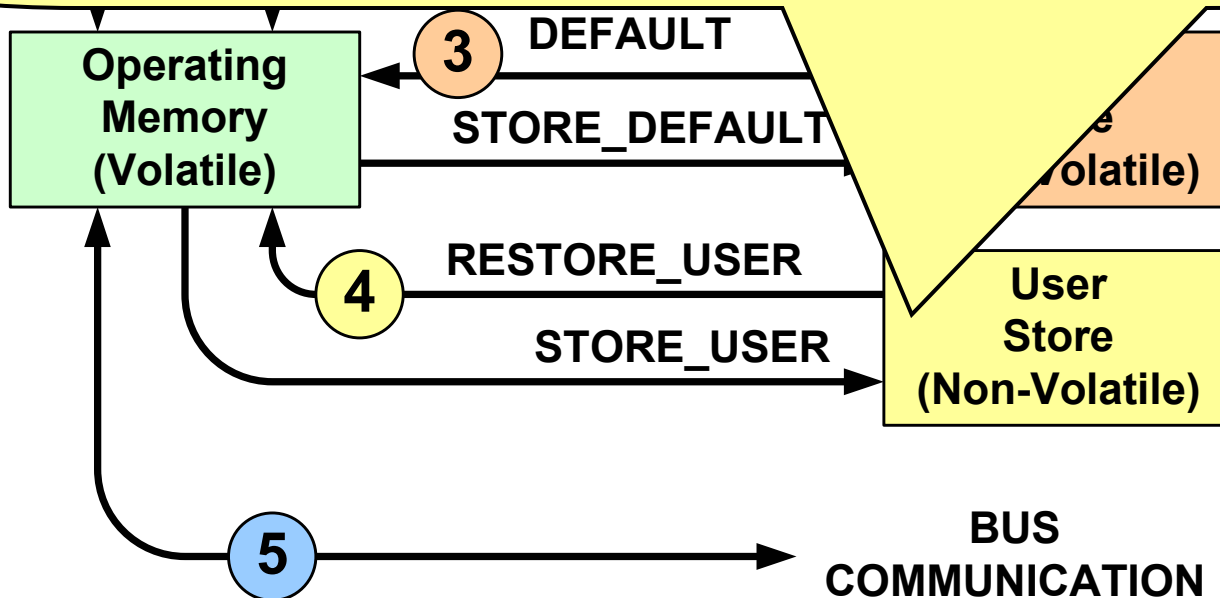

Setting The Output Voltage

- Two Step Process
- Step 1: Set Or Determine Voltage Command Mode
- Step 2: Send Output Voltage Command

- Output Voltage Command Modes
 - Linear In LSB
 - Popular VIDs
 - “IPMI Like” Equation Mode

On/Off Control

- Two Inputs Control Whether A PMBus Device Is Operating Or Not
 - Hardwired CONTROL Pin (Programmable Polarity)
 - OPERATION Command From The Bus
- On/Off Control Totally Programmable
- CONTROL Pin Options
 - Active High Or Active Low
 - Followed Programmed Sequencing Or Shutdown Immediately

On/Off Control Options

- “Always On”
 - Device Providing Output Power Anytime Input Power Is Present
- Respond To CONTROL Pin,
Ignore OPERATION Command
- Respond To OPERATION Command,
Ignore Control Pin
- Respond To Both CONTROL Pin
And OPERATION Command
 - An “Off” From Either Turns Output Off

OPERATION Command Data Byte

One Command Used To Set Operation Mode: On/Off/Margin

Bits [7:6]	Bits [5:4]	Bits [3:2]	Bits [1:0]	Unit On Or Off	Margin State
00	XX	XX	XX	IMMEDIATE OFF (No Sequencing)	N/A
01	XX	XX	XX	OFF (With Sequencing)	N/A
10	00	XX	XX	ON	OFF
10	01	01	XX	ON	MARGIN LOW (Ignore Fault)
10	01	10	XX	ON	MARGIN LOW (Act On Fault)
10	10	01	XX	ON	MARGIN HIGH (Ignore Fault)
10	10	10	XX	ON	MARGIN HIGH (Act Of Fault)

Group Commands/Operation

- Used When Multiple Units Need To Execute A Command Simultaneously
- One SMBus Transaction Used To Send Commands To Multiple Addresses
 - Sent In One Large Packet Using Repeated STARTs
- Can Be Same Or Different Commands
 - Example: Command One Unit To Margin Low And All Others To Margin High
- Commands Are Executed When SMBus STOP Condition Received

Interleaving

- INTERLEAVE Command Sets

- Group Number
- Number Of Units In The Group
- Switching Order Within The Group

Example Of INTERLEAVE Command Operation

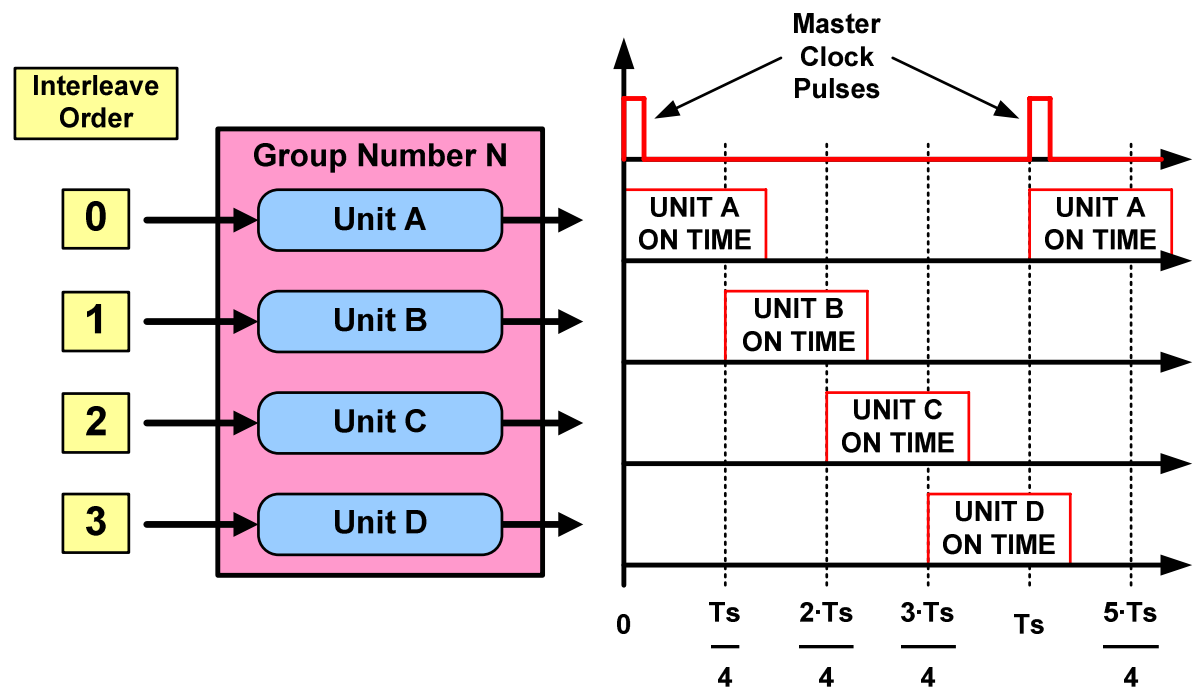

$$T_{delay}(\text{Unit } X) = \frac{\text{Interleave Order Of Unit } X}{\text{Number In Group}} \cdot T_s$$

Many Other Configuration Commands

- Maximum Output Voltage
- Maximum Output Power
- Voltage Scale For External Divider Network
- Maximum Duty Cycle
- Switching Frequency
- Turn On/Off Levels For Input Voltage
- Current Scale For Current Sense Resistance
- Current Measurement Calibration

Sequencing: Event Driven

- Event Driven Sequencing Is Closed Loop
- Requires Power System Manager To Close The Loop

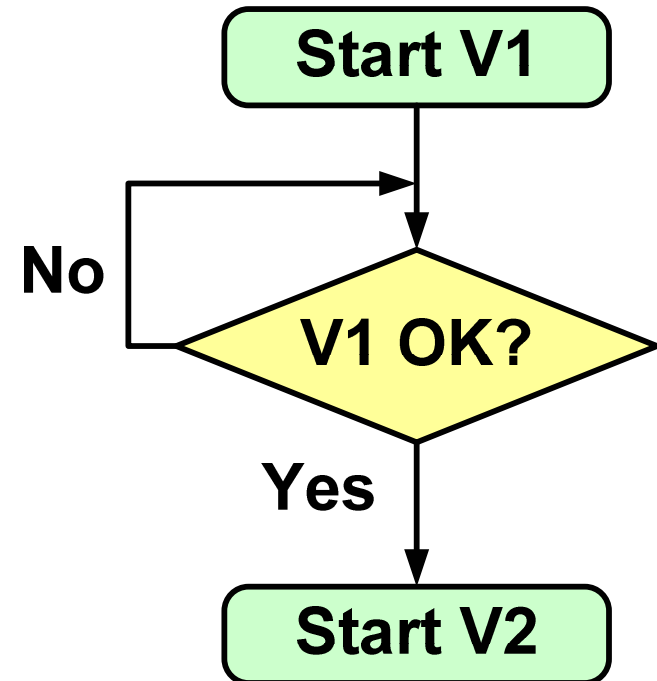
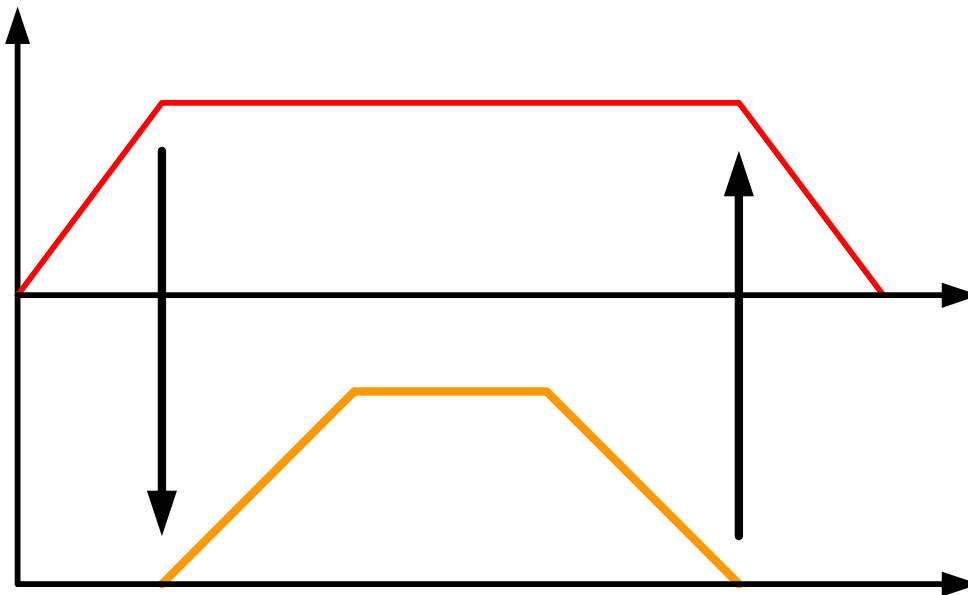

Sequencing: Time Driven Commands

- Open Loop: Does Not Require Power System Manager

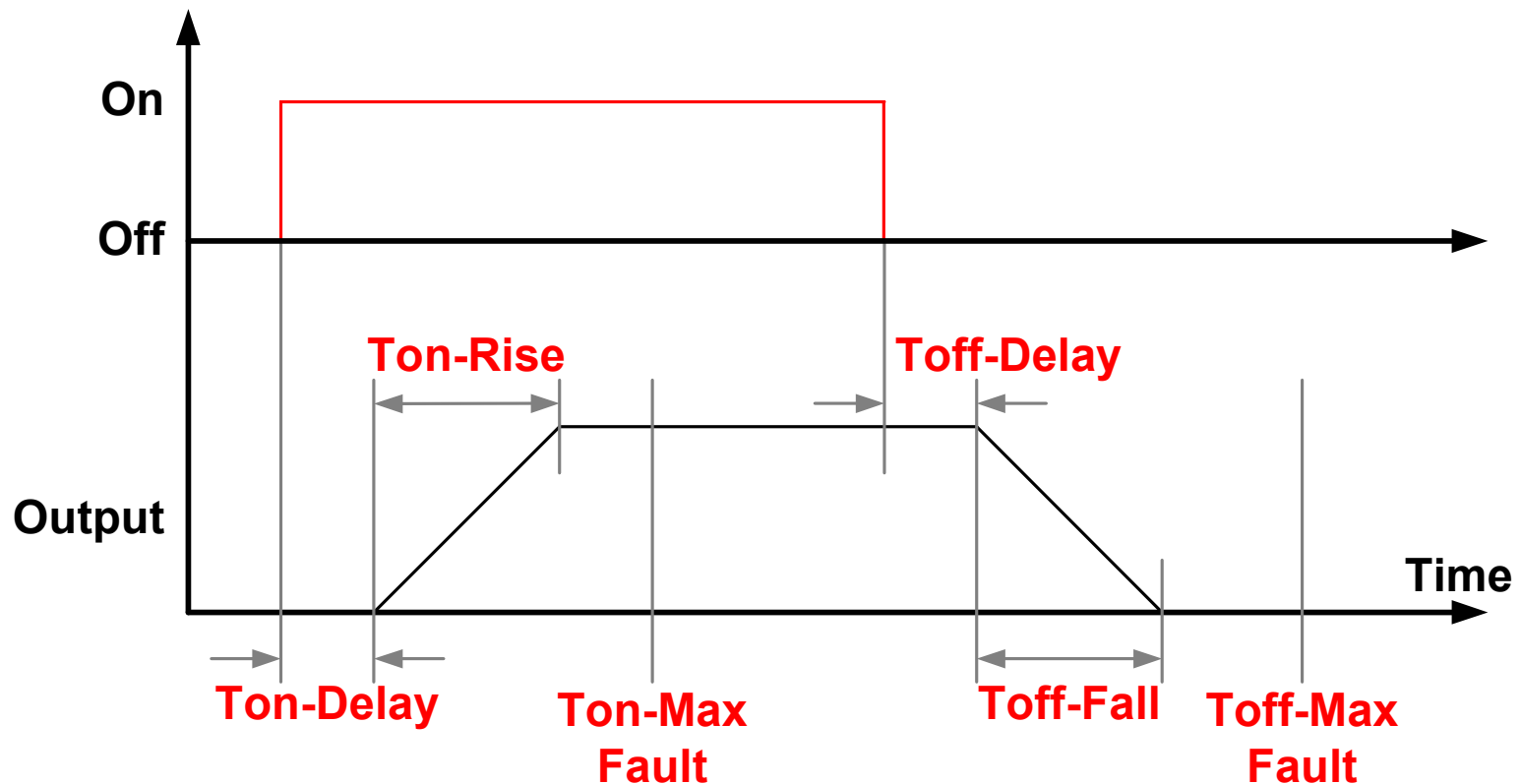

Fault Management: Input

Voltage

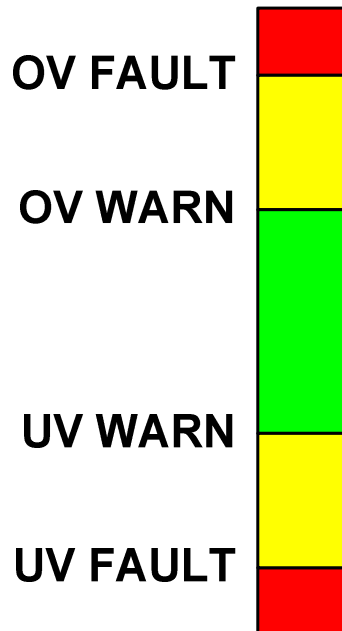

Current

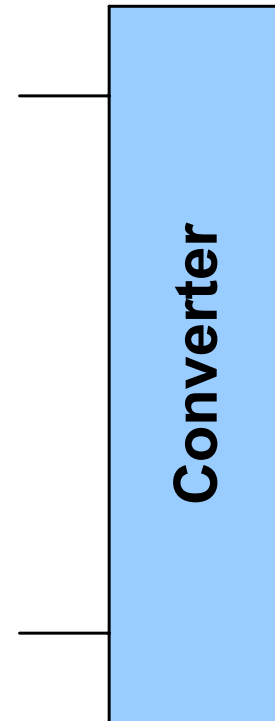
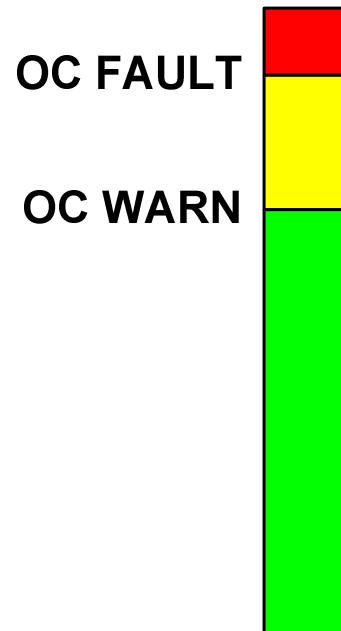

Related Commands: VIN_ON, VIN_OFF

Fault Management: Input

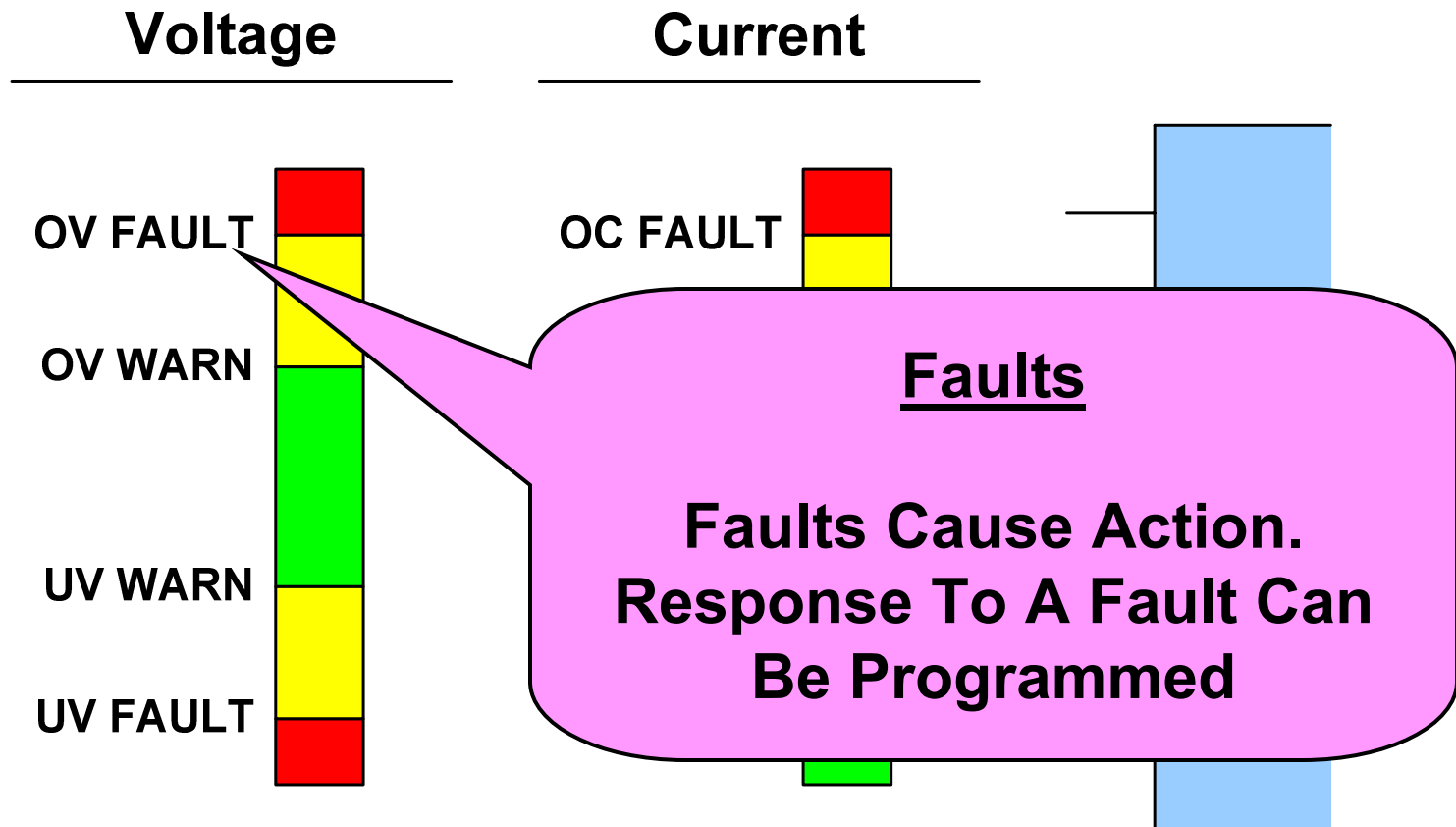

Related Commands: VIN_ON, VIN_OFF

Fault Management: Input

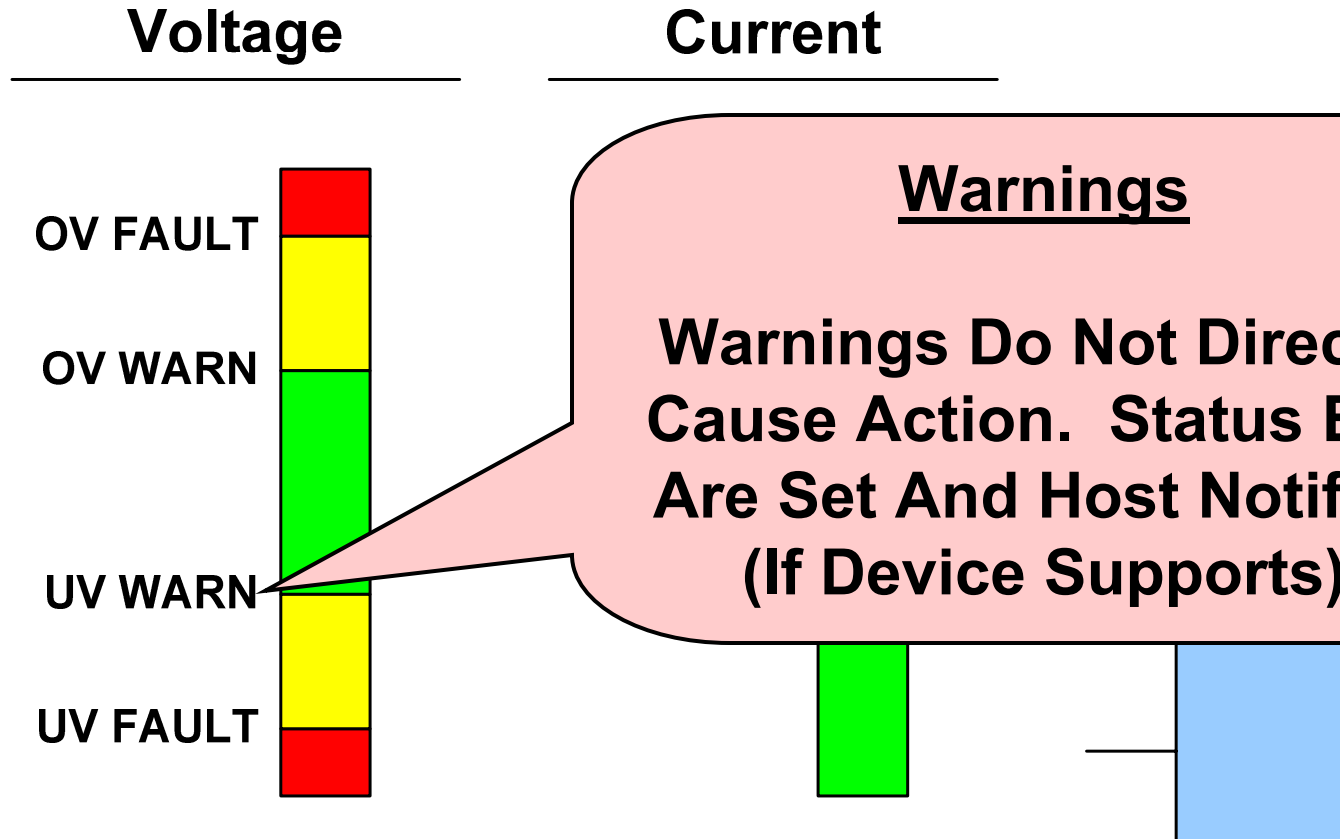

Related Commands: VIN_ON, VIN_OFF

Fault Management: Output

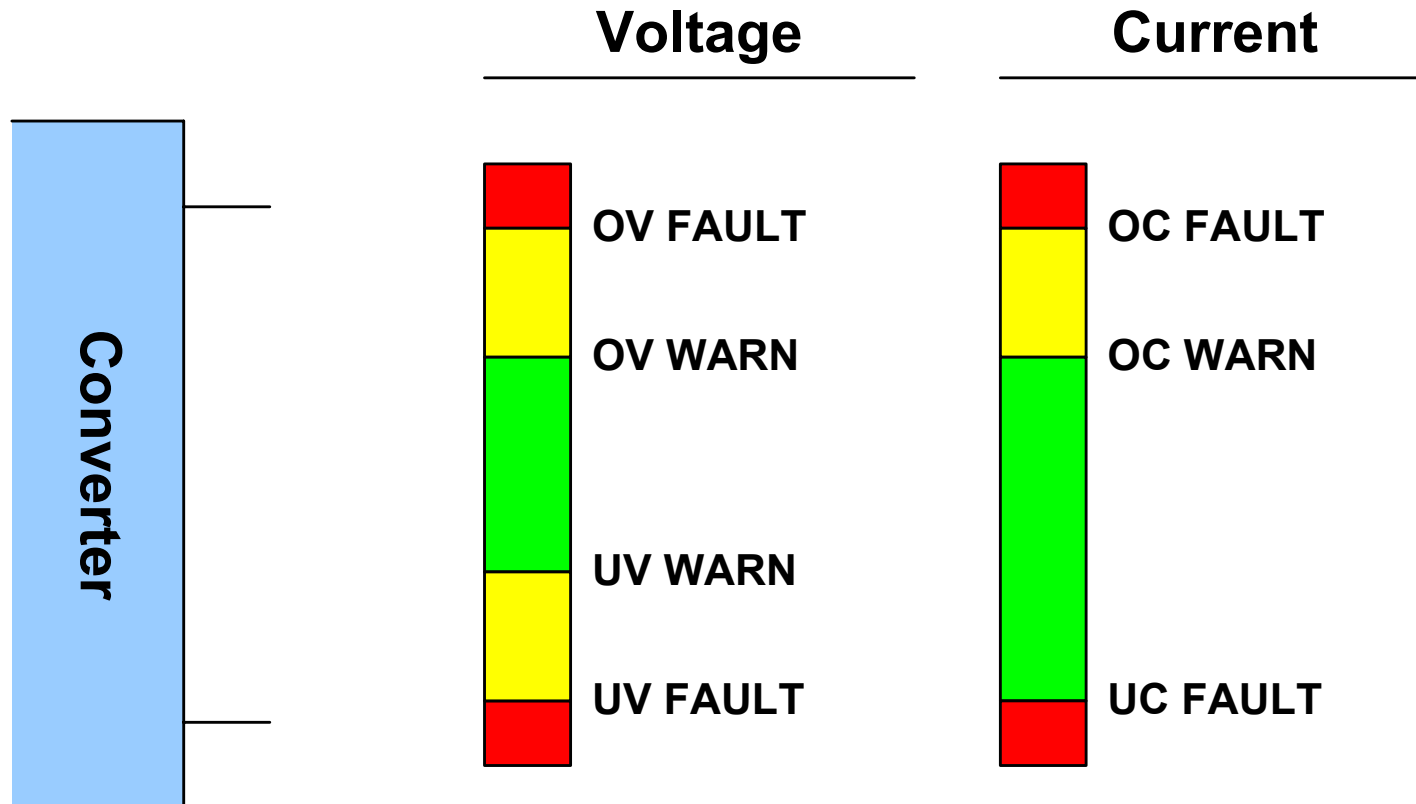

Related Commands:
POWER_GOOD_ON, POWER_GOOD_OFF

Other Fault Management

Temperature

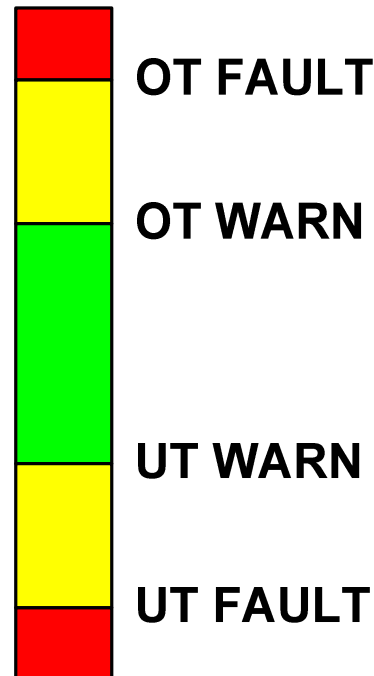
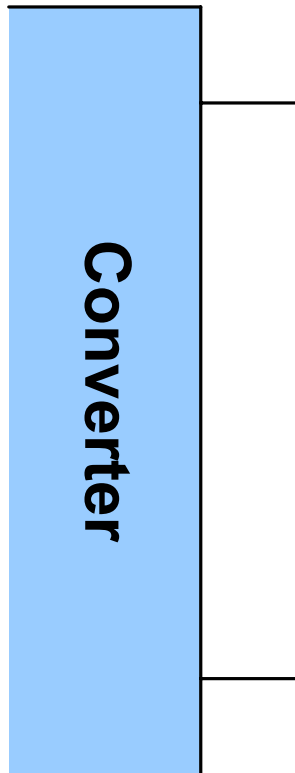

Other Faults

- Fan Fault 1
- Fan Fault 2
- Current Share
- Power Limiting
- Communication

- And more...

Fault Response Programming Byte

RESPONSE

00 - CONTINUE
01 - DELAYED OFF
10 - SHUTDOWN & RETRY
11 - INHIBIT

DELAY TIME

XXX - NUMBER OF DELAY
TIME UNITS

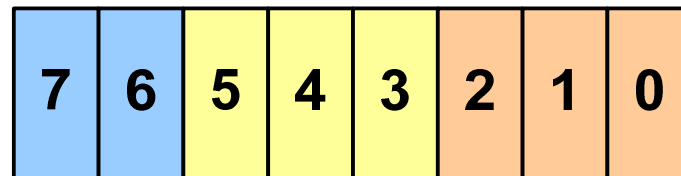

RETRY

000 - LATCH OFF
001 - 110: RETRY COUNT
111 - CONTINUOUS

Notifying The Host Of A Fault

- Host Can Continuously Poll PMBus Devices
- PMBus Device Can Send An Interrupt
 - SMBALERT# Signal Is Optional
 - See The SMBus Specification For Details
- PMBus Device Can Become A Bus Master And Transmit Notice To System Host
 - Optional
 - Requires A More Sophisticated Host

Handling Unsupported Commands & Bad Data

- Choice 1
 - PMBus Device NACKS Command Or Data Byte
 - Reason Put Into Status Registers
- Choice 2
 - PMBus Device ACKs Everything, Processes Later
 - If An Unsupported Command Or Data Out Of Bounds Is Received:
 - Set CML Bit In STATUS_BYTE
 - Set Appropriate Bit In Status Registers (If Supported)
 - Notify Host (If Supported)

Status Reporting: 3 Levels Of Detail

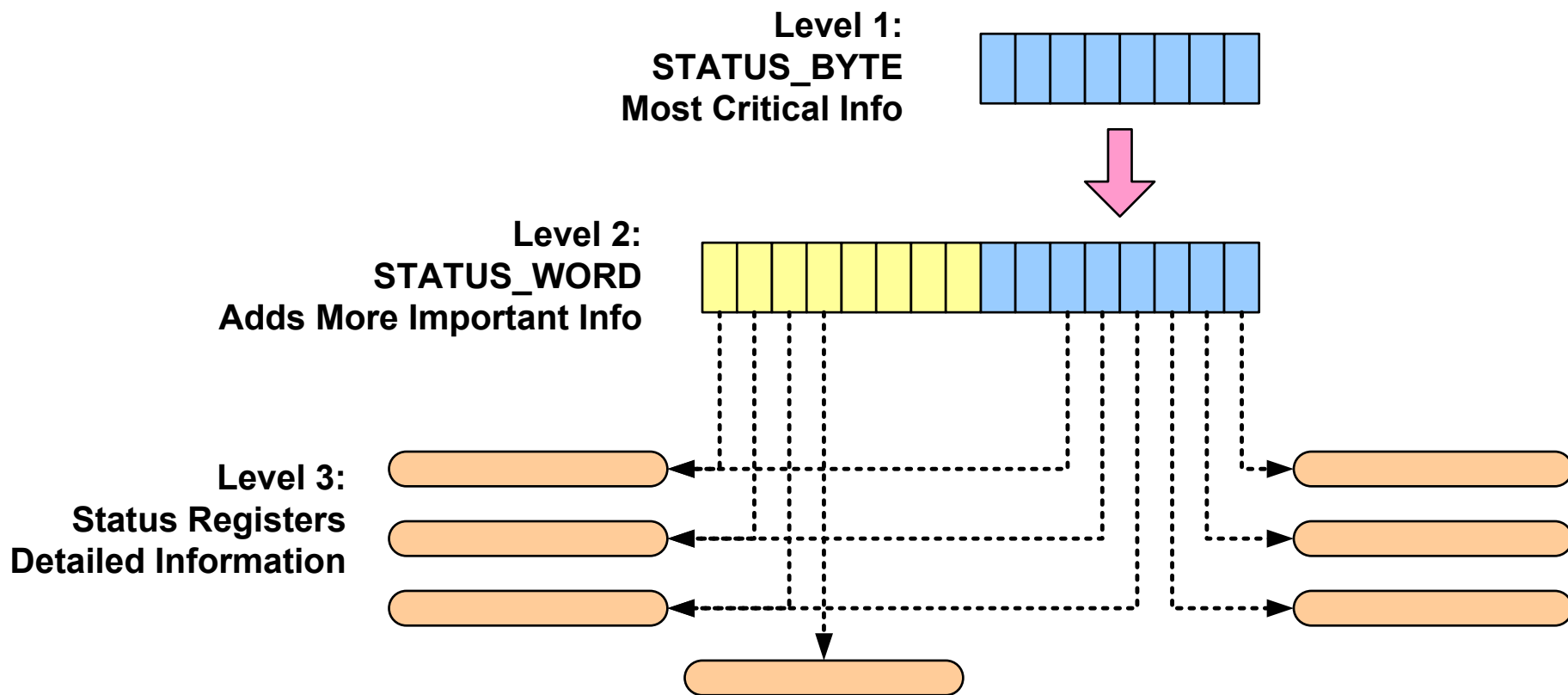

STATUS_BYTE & STATUS_WORD

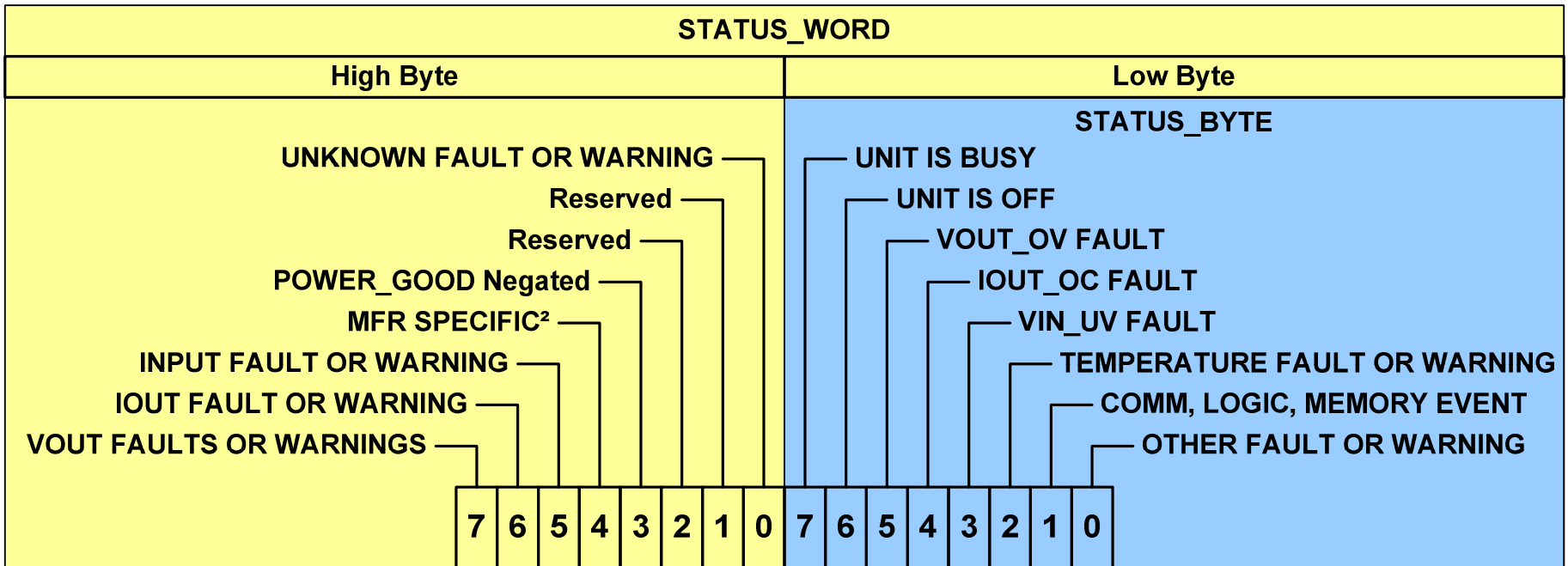

Status Registers

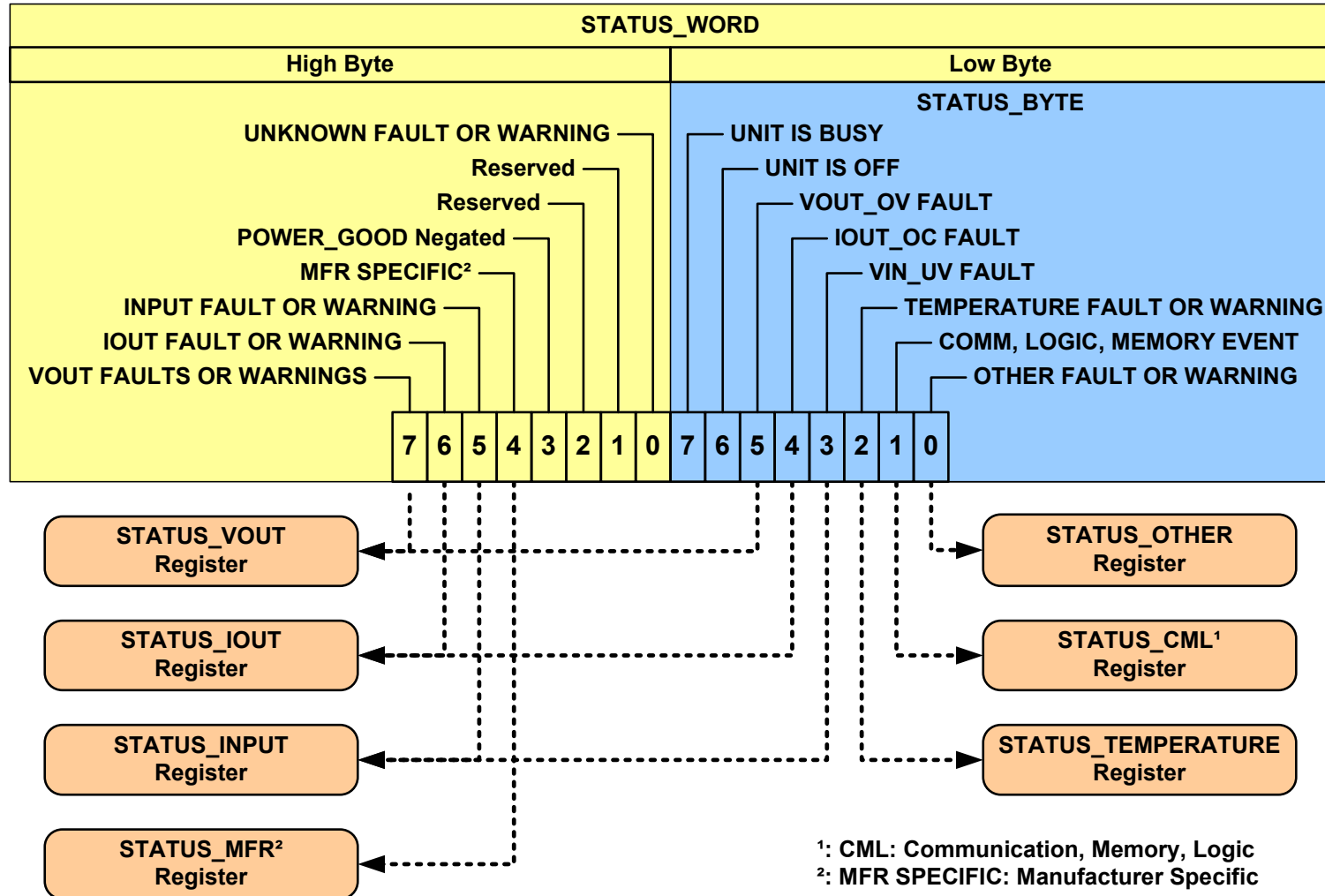

Parametric Information

- Input Voltage
- Input Current
- Output Voltage
- Output Current
- Hold Up Capacitor Voltage
- Temperature
 - Up To 3 Sensors
- Fan Speed
 - Up To 2 Fans
- Duty Cycle
- Switching Frequency

Parametric Information

- Input Voltage
- Input Current
- Output Voltage
- Output Current
- Hold Up Capacitor Voltage
- Temperature
 - Up To 3 Sensors
- Fan Speed
 - Up To 2 Fans
- Duty Cycle
- Switching Frequency

REMEMBER!

**Not All PMBus
Devices Will
Support All
Commands!
Support Based
On Application
And Price Point**

Manufacturer And User Data

- **Manufacturer's Information**
 - Inventory Information (Model Number, Etc.)
 - Ratings Information (Input Voltage Range, Etc.)
- **User Data**
 - 32 Command Codes For PMBus Device Makers To Support User Inventory And Configuration Data
 - Example: Digital Control Loop Coefficients
- **Manufacturer Specific Commands**
 - 45 Command Codes Reserved For PMBus Device Makers To Implement Manufacturer Specific Commands

Data Integrity And Security

- Protecting Against Corrupted Transmissions
 - Packet Error Checking Can Be Used
- Unwanted Or Unintentional Data Changes
 - Write Protect Pin
 - WRITE_PROTECT Command

Summary

- PMBus Is A Flexible, Powerful Tool For Digital Power System Management
- Supports Both Embedded, Discrete Converters As Well As Complete, Purchased Converters
- Has The Features Needed By Nearly All Users
- Application Oriented Feature Sets Control Cost

**More Information And Specifications At:
www.powerSIG.org**